

2026 RULES AND REGULATIONS

PRO TRUCK DIVISION

Saskatoon Stock Car Racing Association
(S.S.C.R.A)
216-510 Cynthia Street
Saskatoon, SK S7L 7K7
(306) 956-3212



Effective January 2026

MISSION STATEMENT:

“To provide members a motor sports and entertainment facility to showcase their talents and abilities, while providing our fans, corporate partners, sponsors and media a valuable entertainment experience.”

RULEBOOK DISCLAIMER

The rules and/or regulations set forth in this book are designed to provide for the orderly conduct of racing events and to establish minimum acceptable requirements for such events. These rules shall govern the condition of all events, and by participating in these events, all participants are deemed to have complied with these rules. NO EXPRESSED OR IMPLIED WARRANTY OR SAFETY SHALL RESULT FROM THE PUBLICATION OF, OR COMPLIANCE WITH THESE RULES AND/OR REGULATIONS. They are intended as a guide for the conduct of the sport and are in no way a guarantee against injury or death to a participant, spectator or official.

The Competition Director together with Competition Committee, on behalf of S.S.C.R.A., shall be empowered to permit minor deviation from any of the specifications herein or impose any further restrictions that in their opinion do not alter the minimum acceptable requirements. NO EXPRESSED OR IMPLIED WARRANTY OF SAFETY SHALL RESULT FROM SUCH ALTERATIONS OF SPECIFICATIONS. Any interpretation of, or deviation(s) from these rules shall be left to the discretion of the officials. Their decision is final.

Saskatoon Stock Car Racing Association

(S.S.C.R.A.)

Lines with ‘strikeout text’ (~~strikeout~~) in RED are rules that have been removed.

Lines highlighted in YELLOW are rules that have been modified this year.

Table of Contents

CODE OF ETHICS.....	4
Race Day Technical Inspection Procedures	5
Pro Truck Concept.....	6
1. Build Guidelines	7
2. Body	7
3. Bumpers and Tow Straps	8
4. Frame	8
5. Roll Cage.....	8
6. Interior	9
7. Suspension	9
8. Steering	10
9. Fuel System	11
10. Engine.....	11
11. Carburetor.....	13
12. Air Intake.....	13
13. Exhaust.....	14
14. Cooling System.....	14
15. Electrical.....	14
16. Transmission	14
17. Driveshaft.....	15
18. Differential	15
19. Brakes.....	15
20. Wheels and Tires.....	16
21. Ballast.....	17
22. Safety	17
23. Electronics.....	17
Diagrams	18

CODE OF ETHICS

Purpose

To act in a professional manner so as to bring a positive image to the public and fellow members of the sport of stock car racing and to realize the need for a reasonable and responsible personal code of 'unwritten laws' since laws cannot cover all situations.

Expectations

1. Respect **MUST** be had for all traffic laws and criminal codes, such as not drinking and driving.
2. No alcohol, drugs, or stimulants allowed in association with your car or team when in the public eye.
3. No verbal or physical abuse towards any person when connected with a stock car event, display or promotion.
4. When dealing with the public, courtesy and cooperation should be shown to promote the sport in a positive light at all times. For example, do not approach another person's sponsor(s).
5. All members should be clean and presentable when in any public situation.

Definition of Behavior

Anyone who, by word or deed, impedes, jeopardizes, or in any manner hinders the smooth and orderly presentation of the racing program - or - anyone who commits, or causes to be committed, any detriments to stock car racing, the S.S.C.R.A. will consider that person(s) to have abused the privileges of membership, entry and/or admission granted by the S.S.C.R.A. and that they may be subject to the revoking of those privileges and/or disqualification as deemed proper by the Executive or designated official. Drivers are responsible for the sportsmanlike conduct of anyone in their crew and penalties incurred by a crewmember may affect the driver.

Race Day Technical Inspection Procedures

1. Scale access:

Prior to the **first feature race** of each race event, the technical inspection station will be accessible to competitors for weight and other checks by either the individual teams or Technical director / inspectors by request.

2. Protest Procedure:

A protest **must** be submitted in writing, to the race Technical director / inspectors at any time through a race day and no more than 15 minutes after the completion of the last race (feature) of the event day. *** Protest forms are available at the in the infield Technical office.

3. Technical inspection: General

- a. Any vehicle may be called to inspection at any time. If directed to Technical inspection station, compliance is mandatory. Non-compliance will bring disciplinary action.

Driver not required in car:

1. Safety equipment dates and certifications.
2. Tires
3. Wheelbase and track width
4. Rear spoiler
5. Engine location
6. Create engine seals
7. Items unrelated to driver.

Driver required in car:

1. Safety equipment fit and placement (Head rest or safety belt fit test)
2. Weights and percentages
3. Roof, skirt, frame and nose heights
4. Fuel cell to ground clearance

4. Technical inspection: Post race

- a. **Top five three** and random choices.

The top **five three** finishers of each feature race **MUST** go directly to the technical inspection station. Any car and driver directed to the technical inspection station **MUST** comply. Failure to go directly to the technical inspection station will result in **automatic DISQUALIFICATION**.

Post race inspected items may include but are not limited to:

1. Weight and balance
2. Carburetor
3. Tires
4. Shocks
5. Engine
6. Any component technical inspector chooses.

5. SSCRA Technical / Competition Committee may make minor amendments to this rule package for clarification as required.

NOTES:

1. Top 3 in a Club Event **MUST** go to tech line or disqualification will be automatic. Top 5 **MUST** go to tech at Special Events
2. Anyone waved to tech line after race, **MUST** go directly to the tech area, or disqualification will be automatic.

2026 Pro Truck Rules

The Pro Truck division: starts life not as a factory pickup truck but is built as a racing vehicle. Chassis and suspension components are utilized from a GM metric chassis. The body of a Pro Truck is an aftermarket fiberglass racing reproduction of newer style Ford, Chev, Dodge, or Toyota full size pickup trucks. The wheelbase is 108-inch car chassis with modifications allowed for adjustability and performance such as weight jacks.

The rules in this document must be used in combination with Saskatoon Stock Car Racing Association 'General Rules and Safety Rules'. Any variations are subject to approval of the Competition Committee. Any violations found are to be corrected by next race meet. Further disciplinary actions to be determined by the Competition Committee as warranted.

1. Build Guidelines

- a) **Minimum Weight:** All trucks must have a minimum weight of 3,000 lbs. at any time. Maximum left side weight is 55.0% measured at any time. ~~Front weight must be a minimum of 52%.~~ Weights **MUST** be taken with driver in seat with helmet and **full of fuel**.
- b) **Minimum ride height:** 5" at lowest point of frame side rail with driver **in truck**.
- c) Maximum track width allowed is 75", measured to the outside of the tires at 3/9 o'clock of the tire side wall. Tires **MUST** stay within confines of the body at 3/9 o'clock and above.

2. Body

- a) All Pro Truck bodies must be after market, plastic, fibreglass or aluminum construction, regular cab or extended cab.
- b) Body ground clearance will be a **Minimum** four inches, measured at the center most point on the nose of the truck between the headlights with driver. Body location must be centered left to right within 1" of the chassis/frame centerline.
- c) Maximum overall width of 81" measured from the outside of the body material along the sides of the truck.
- d) Maximum overall length of 200" and minimum overall length of 190" measured from center of nose cone to center of rear bumper.
- e) Box cover must be a minimum 22-gauge sheet steel, aluminum or fibreglass.
- f) Polycarbonate side rub rails between front and rear wheel wells allowed. Rub rails must be cut to angle on each end to remove sharp edges.
- g) Windshield must be minimum 1/8" Lexan or equivalent. Extended cab and rear window openings: if enclosed must be a minimum of 1/16" Lexan or equivalent suggested.
- h) All windows must be securely fastened with fasteners spaced a maximum of 6" apart using 3/16" large flange rivets or equivalent.
- i) All windshields **MUST** have a minimum of two (2) safety rods on the inside of the windshield, 1/2" diameter rods or 3/8" black pipe spaced a minimum of 10" apart centered on windshield.
- j) No door opening window covers allowed.
- k) The maximum rear spoiler material size is 6" tall measured along its face x 60 inches wide. Minimum 0.100 inches thick. The bottom of the spoiler at the bend may not extend past the rear of the body.
- l) The spoiler must remain straight, no curved or adjustable spoilers, and no side wings. All sharp edges must be removed from the spoiler surfaces.
- m) No "Gurney Lip, Wicker Bill" or any additional parts may be added to the spoiler to enhance effectiveness or performance.
- n) If an Earnhardt bar of 1.75" x .095" roll cage material is used, the interior windshield supports are not necessary.
- o) Roof height minimum of 55" at a point 10" behind top centre of windshield.

3. Bumpers and Tow Straps

- a) Only one (1) front bumper bar maximum 1.75" x .095" allowed, rear the same.
- b) Bumper bars must be formed to fit the contour of the nose and tail cone,
- c) Maximum 1.75" x .095 grill bar mounted behind the grill is allowed. Upper (grill) and lower (bumper bar) bars **must be independent** may be minimally connected to protect radiator, to a limit, at the discretion of the Tech Committee.
- d) Four tow straps are mandatory with two on the front and two on the rear of each truck.

4. Frame

- a) Chassis/Frame must be a 1978-1988, 108-inch wheelbase GM metric "G" Body. *Part # for OEM Frame to follow.* **No fabricated frames.**
- b) All GM "G" metric chassis stock suspension mounting locations must be used.
- c) Must remain square to OEM specification and measurements.
- d) Allowable modifications: boxing of side rails. Xing of the center bay and or cross bracing.
- e) Front frame horn modifications allowed. Must be a minimum of 16" forward of the "K" member front surface.
- f) Notching of the front spring pockets for shock clearance is allowed.
- g) Replacement of the rear section from the center line of the rear axle rearwards to the rear side of the original chassis/frame allowed, must maintain a minimum ground clearance/height of 12". Chassis/frame replacement minimum acceptable materials 2" x 3" x .125" rectangular steel tubing OEM rear springs and shock perch/mounts must remain in its entirety in OEM location and configuration. Tabs may be added to the frame mount for mounting of rod end style shock.
- h) Engine cross member on the frame may be notched to accommodate Ford or Dodge oil pan.
- i) Only one (1) **front bar**, maximum 2" OD may be added in between and no wider than the frame horns, mounted behind bumper is allowed.
- j) *See Diagram at end of Pro Truck Rules*

5. Roll Cage

- a) Six-point roll cage of mild steel, gusseted, fully welded construction only. All welds must be 360 degrees.
 - i) Kit Cage CSC-RCK501-4 (*suggested*)
 - ii) *<See General Rules Diagram 1a>*
- b) Minimum roll cage construction is 1.75" x 0.095 round ERW 1010 mild steel tubing. Kit cages constructed of 1.75" x 0.095 mild steel tubing strongly recommended.
- c) **MUST** have a dash bar and a cross bar behind the driver.
- d) Rear edge of B pillar located no more than 86" from the ball joint grease fitting on the lower control arm at ride height Minimum of three (3) driver door bars with two (2) rows of vertical connecting bars on the driver side extending to the frame or rocker panel and two (2) passenger side door bars. The entire **driver's door area**, which includes the area from the "A" pillar post to the "B" pillar post and from the top door bar to the frame, **MUST** be filled with 1/8" steel plate. Pieces **MUST** be securely welded on the outside &

overlap the door bars for all new builds; 2013 and older will be grandfathered in. If there is no factory kick plate, a steel plate shall replace it.

- e) Cage **MUST** have a bar from the top of the door bar to the cage A-pillar. <See diagram 2A General Rules>.
- f) Main cage halo dimensions: Maximum 12" from the right edge of the roof skin. Maximum 3" down from roof skin, within a 3" perimeter. <See diagram 2A General Rules>.
- g) For all trucks built 2015 or later, the roll cage must include the Earnhardt bar (a vertical bar that extends from the horizontal dash bar to the halo). ~~Or may be installed on front to back on top of the halo diagonally or straight across to prevent collapse from impact on rollover, but still must allow for extraction of the driver through the roof.~~ This bar must be constructed of 1.75" x ~~0.095~~ **0.090**. See diagram 2a under General Rules.
- h) Cages must mount to the frame rails (left and right) and extend upwards plumb to the chassis for at least 20".
- i) Engine bay front hoop allowed with a maximum of three (3) support bars per side.
- j) **Aluminum oval track racing bucket seat** with right-side head support, properly mounted to the roll cage is mandatory. Minimum distance of 36" from rear of seat to center of differential. Full containment head rest recommended. <See Diagram 6B General Rules>.
- k) Mounting and location of shoulder belts. <See Diagram 5B General Rules>.

6. Interior

- a) Steel fabricated interior allowed 22-gauge steel minimum.
- b) Interior must be sealed from the engine compartment and undercarriage area.
- c) Passenger floor may be constructed from the top of the drive shaft tunnel and go horizontally to the right to the inside of the passenger front and rear main hoop cage tubes. The remaining gap to the door can be filled with a vertical panel going up to the top of the door and be attached to the door with a filler across to the right side.
- d) Maximum drive shaft tunnel height is 12" from the top of the frame.
- e) No bathtub style interiors allowed.
- f) Must allow right side access for safety personnel.
- g) Factory floor pan may be used if desired.

7. Suspension

- a) All GM "G" metric chassis stock suspension mounting locations must be used.
- b) Sealed, steel body, non-adjustable, non-rebuildable shocks only; no re-valving. Steel welded bearing only.
- c) No adjustable shocks of any kind. Examples of approved shocks: Monroe SSF and SSC, Pro W/B series, AFCO 1200 & 1400 series, Integra 4200 series, Carrera/QA1 55 & 59 Series Any other shocks must be taken to the tech advisor for approval.
- d) Shocks must run as produced and provided by manufacturer.
- e) Fixed bearing steel shock absorbers may be used and rear shock must remain in stock location.

- f) **Adjustable weight jacks allowed.**
- g) Spring pockets must remain in stock location.
- h) Spring buckets may be used.
- i) No eccentric bushings

j) **Front**

Only GM "G" metric lower control arms ~~and factory length lower ball joints, to be used without any modifications to any parts. May use any GM spindle provided it is one piece cast or forged magnetic steel. May use any after market steel hub.~~ **Spindles may be stock or aftermarket. Must be cast or forged. Must be magnetic steel.**

- i) ~~Only rubber or poly urethane bushings may be used in lower control arms.~~ **Stock, steel, polyurethane, bearing type or mono-ball bushings may be used.**
- i) ~~No Adjustable ball joints, only stock appearing "bolt in" greaseable ball joints.~~ **No mono-ball spacer adjustable ball joints; only stock appearing greaseable ball joints allowed. Stock appearing or screw in ball joints permitted.**
- ii) Aftermarket tubular upper control arms with solid bushings allowed with mounting holes and pivots locations on the same axis plane.
- iii) Any **GM** sway bar that mounts in stock location ~~without alteration~~ may be used.
- iv) **Sway bar may have threaded adjustment on one end and Heim joint on the other end.**
- v) No hollow or racing sway bars allowed.
- vi) ~~No~~ Heim joints allowed on the sway bar linkages.
- vii) ~~Sway bars may be adjustable only at the link end~~
- viii) ~~Centre link—must be stock or OEM replacement number~~

k) **Rear**

- i) Rear OEM control arms may be boxed with 1/8" flat metal on the underside.
- ii) One 1/2" SAE flat washer may be welded to the diff end of the upper control arms to strengthen original mounting holes.
- iii) ~~OEM rear upper and lower control arms must be original length.~~
- iv) Only rubber or poly urethane bushings may be used.
- v) ~~After market rear control arm option allowed: part #91634057(78-88GM "G" body rear control arms with poly urethane or OEM bushing by Speedway motors, upper arm length of 11 1/4", lower arm length of 19 3/4")~~
- vi) ~~No mixing of stock and aftermarket control arms.~~
- vii) No rear sway bars allowed.
- viii) A lifting chain with a minimum of three (3) inches of slack will be allowed.
- ix) After market adjustable **top upper and lower** links may be used. ~~Must be tack welded after adjustment.~~

8. **Steering**

- a) All steering components must be stock to car, in stock location. No welding of parts.

- b) Steering column **MUST** be collapsible. Quick release steering wheel mandatory. **No factory rag joint allowed.**
- c) G metric centre link to be stock OEM or OEM replacement.

9. Fuel System

- a) A fuel cell is **mandatory**, must consist of a plastic or rubber bladder
- b) Fuel cell must be boxed in a 20 gauge steel container.
- c) Maximum fuel capacity of 22 US gallons.
- d) Must be mounted behind the differential, between the frame rails as forward as possible.
- e) Fuel cells to be mounted a minimum of 10" from the ground to the bottom of the fuel cell.
- f) Fuel cell minimum mounting **MUST** use a minimum 1"x1"x1/8" square tube structure two (2) horizontal tubes and 2 fore and aft tubes closely fitting the outside of the steel container.
- g) All fuel cells must be grounded and caps tethered.
- h) **Rear fuel cell guard bar mandatory.** This bar drops down from the rear most cross member, a minimum of even with the lower surface of the fuel cell, running side to side, the width of the fuel cell to protect from impact damage.
- i) Any variations are subject to approval of the technical committee.
- j) Remote filler securely mounted under the deck lid; optional.
- k) Only pump fuel available at your local consumer outlets will be permitted. No oxygenation, aviation fuel or race fuel will be permitted. Octane boost is permitted.

10. Engine

- a) **Fuel pump:** Stock mechanical pump only. Absolutely no electric fuel pumps. No glass or plastic fuel filters allowed. No "Cool Cans".
- b) **Distributor:** Only stock distributor and stock coil allowed. No external modules (except Ford) or external modifications. No modifications to stock mounting of module. GM HEI style allowed in all makes. Traction devices, not allowed. Rev limiters allowed for ignition systems. RPM to be determined. MSD part # 8727CT. in 2019.
- c) **Harmonic balancer:** **MUST** be OEM style.
- d) **Engine Location:**
 - i) Measured from the forward most spark plug hole centerline (cylinder #1), to the front of the chassis cross member, where cross member is welded to the front frame horn.
 - ii) Ford, the cylinder #1 sparkplug centre hole shall be no more than 4.50 inches behind the front side of the cross member, plus or minus 0.25 inch.
 - iii) Chevrolet, stock location or 0.25 inch behind the front of the cross member, measured from cylinder #1 sparkplug centre hole, plus or minus 0.25 inch.

- iv) Dodge, 4.50 inches behind the front of the cross member, measured from cylinder #1 sparkplug centre hole. Note: All models, engine location tolerance plus or minus 0.25 inch.
- v) Alternative measurement procedure: From forward face of bell housing to front of differential axle tube. (to be determined in 2015). See diagram "E"

e) **Open Engine**

- i) Interchange of engines between makes allowed. Marine parts are not permitted.
- ii) **Engine Block: MUST** be a cast iron OEM block with exception of permissible overbore. An OEM lifter bore **MUST** be maintained. De-burring of block and parts permitted. Block **MUST** maintain -0.015" deck height (GM).

iii) Make	Max Overbore	Max CID	Head CC
GM 305	0.060"	315 cid	58cc
GM 327	0.060"	334 cid	64cc
GM 350	0.060"	360 cid	67cc
Dodge 360	0.060"	370 cid	64cc
Ford 302	0.060"	307 cid	54cc
Ford 351w	0.060"	362 cid	57cc w/-13 cc dished piston
Ford 351w	0.060"	362 cid	64cc w/ flat top piston
Ford 351c	0.060"	362 cid	64cc
Indy 360 LA-X	0.060"		62cc w/ 18cc dished piston

- iv) **Crankshaft: MUST** be OEM. Aftermarket cast steel crankshaft allowed. **MUST** weigh within 3% of OEM crankshaft (OEM weights GM – 51 lbs., Dodge – 56 lbs., Ford 351 Windsor – 56 lbs., Ford 302 – 38 lbs. Ford Cleveland - 55.8 lbs.). Absolutely no aftermarket forged, race type or exotic crankshafts allowed.
- v) **Connecting Rods:** Aftermarket connecting rods allowed. De-burring of stock rods is permissible. Stock rod length to the OEM block being used.
- vi) **Pistons:** Flat top or dished only, weighing a minimum of 1,200 g each with the wristpin, rings, connecting rods and bearings. All pistons **MUST** have two(2) compression rings and an oil ring.
- vii) **Camshaft:** Flat tappet hydraulic cam and lifters only. Stock OEM style push rods. No roller lifters allowed. Roller rockers are not permitted. NO gear drive or belt drive.
- viii) **Cylinder Heads:** Only stock cast iron OEM castings permitted or the following stock replacement heads: **GM** - Dart 10024361 or 10024361A, World Products 043600-S/R (76cc), 043610-S/R (67cc), 042650-S/R, 87 and newer 042750-S/R (58cc). **Ford** - World Products Windsor JR. 053030 (58cc), **Dodge** - Indy 360-LAX cylinder head allowed. If used, the pistons must have a minimum of an 18CC dish. Absolutely no de-burring, grinding or polishing of intake or exhaust ports permitted. Chevrolet engines are restricted to 1.94" intake valve diameter and 1½" exhaust valve diameter. All other engines **MUST** be stock for year and engine model used. Guide plates are permitted. The maximum Chevrolet valve spring diameter permitted is 1.266". Composition head gaskets of no less than .026" compressed thickness for Chevrolet only. All other makes is .039". Chevrolet Vortec and

Dodge Magnum allowed. 350 Chevrolet Vortec engines must run no less than 0.039" head gasket. Early Ford GT-40 or 4bbl Cleveland not allowed. Non-metallic valve train parts not allowed.

- ix) **Oil pan:** Any steel wet sump oil pan that fits with no modifications to frame is permitted. Oil filter **MUST** be OEM style for block and mount in OEM location.
- x) **Intake Manifold:** Only stock OEM cast iron 2BBL intakes or *Edelbrock RPM Performer* dual plane high rise aluminum intake (GM - #7101, Ford 351-W - #7181, Ford 302-W - #7121, Ford 351-C #2750 Performer, Chrysler - #7176) or *Weiland Products* dual plane high rise aluminum intake (GM – Stealth #8150, Ford 351-W - Stealth #8023, Ford 302 - Stealth #8020, Chrysler – Stealth #8022) allowed. GM Vortec engines are permitted to use the GM PP602 crate engine manifold. No grinding or coating of any kind permitted, internally or externally.

f) **Sealed Crate Engine**

- i) **GM** circle track 350 engine P/N 88958602 or 19258602. Any engine seal, which is altered or tampered with in any way from the original purchase, will be deemed illegal. Rocker Arm ratio of 1.5:1 and valve springs must be stock. 0.030 shim under valve spring is allowed.
- ii) **Ford** Blue Print Engine #BP3472CT allowed. Engine must be dyno tested on a local approved engine dyno. A member of the Competition committee must be present to verify complying engine specs. The engine will then be sealed before leaving the dyno facility.
- iii) Any engine seal which is altered or tampered with in any way will deem the engine illegal.
- iv) All crate engines must be registered with SSCRA; please see General Rules for Crate Engine Registration form.

11. **Carburetor**

- a) Stock OEM production 2 bbl carburetor or 4412CT Holley 500 CFM 2 bbl carburetor or Quick Fuel 4412 500 CFM 2 bbl allowed.
- b) ~~If Holley 4412 carburetor is used, Canton Racing Products 85-050 (2 bbl manifold) or 95-060 (4 bbl manifold) adapter, or a Moroso 64952~~ Any four-barrel to two-barrel carb adapter may be used.
- c) Space between top of manifold and bottom of carburetor including adapter plate and gaskets shall not exceed 1¼".
- d) Two (2) throttle return springs are mandatory.
- e) Removal of choke parts and changing of jets and power valve is allowed. Accelerator pump cam and nozzles may be changed. No other modifications or alterations to main body.
- f) Metering blocks must be cast only, non-adjustable emulsion holes.
- g) No modifications or alterations to main body, throttle shafts or plates.
- h) No billet carburetor parts allowed.

12. **Air Intake**

- a) Aftermarket drop type air cleaner base may be used to allow hood closing clearance.
- b) Cold air induction is permitted.

e) ~~R2CAC1851059 air cleaner base allowed.~~

13. Exhaust

- a. **Mufflers mandatory.** Maximum noise level of 98 decibels. ~~Trucks that fail to meet the maximum noise level will be required to install a spec muffler prior the next event. Part number to be determined.~~
- b. **All trucks will be required to run spec mufflers in 2022.**
- c. Full length down tube, mid-tube or shorty headers allowed (no cross over headers). Maximum 1 $\frac{5}{8}$ " OD primary tube.
- d. Maximum exhaust pipe size is 2 $\frac{1}{2}$ " OD from the header collector to the muffler.
- e. One (1) connector pipe is allowed, maximum diameter 2 $\frac{1}{2}$ ", after header and before the muffler.
- f. Exhaust must exit behind the cab rear door seam/driver's compartment no higher than 10" from the ground to the top of the exhaust pipe/outlet. Must exit out the side of the vehicle body.
- g. Exhaust outlet may constructed in any format, but must be finished as not to damage tires if side contact is made (see exhaust outlet examples diagram at the end of the rules)

14. Cooling System

- a) **Radiator** may be re-mounted but **MUST** remain in its basic location (ahead of the engine and between the frame rails).
- b) **Overflow Can mandatory** minimum 1 liter, securely mounted.
- c) No coolers of any kind in the driver's compartment.
- d) Mechanical or electric fans permitted. All fans **MUST** be plastic.
- e) **NO ANTIFREEZE! Water wetter allowed.**

15. Electrical

- a) **Battery MUST have a Red Master Disconnect Switch.** Must be **centrally** located in the driver's compartment, for the ease of access by driver and safety crew. Switch should be mounted in the middle of the dash or on the roll bar from the main hoop to the dash bar or front frame (Petty bar). Must be clearly labelled ON/OFF, and **MUST** kill motor and all power. Recommended Switches Allstar # 80158, QuickCar # QRP-55.
- b) **AGM batteries REQUIRED. No Lithium batteries.**
- c) Battery **MUST** be located outside of the driver's compartment but within the wheelbase of the truck and securely fastened. If located in the front or rear firewall, battery **MUST be completely sealed from the driver's compartment** and accessible only from outside the vehicle. Battery fasteners **MUST** be $\frac{1}{8}$ "x1" steel strap or $\frac{3}{8}$ " rod minimum.
- d) **Starter MUST be operational** at all times and mounted in stock position.

16. Transmission

- a) Any stock automatic transmission with a working mating stock style torque converter.
- b) Any stock manual transmission of five speeds or less. All transmissions **MUST** have all gears working.

- c) Transmission adapter plates are not permitted.
- d) Stock clutch disk, pressure plate and flywheel. 10" minimum diameter clutch disk is required. Aluminum clutch parts and aluminum flywheels are not permitted.
- e) No lightening of flywheels. Minimum weight 13 lbs.
- f) A scatter shield or minimum 1/8" thick steel plate, 180° safety shield or blanket mounted over the bell housing bolted to the floor is mandatory for manual transmissions. An aftermarket safety bell housing is recommended.

17. Driveshaft

- a) **Front and rear driveshaft hoops of 360 degrees mandatory.**
- b) Front hoop to be within 6" of front joint, 1/4 x 2" steel minimum, no further than 3" away from the driveshaft circumference
- c) Rear hoop mounted behind the driver's seating location to protect the driver in case of a failure (see drive shaft loop diagram at the end of the rules)
- d) All drive shafts must be painted white.
- e) Stock type steel drive shafts only.
- f) No lightweight, aluminum, chrome moly or carbon fiber drive shafts allowed.

18. Differential

- a) Ford 9" optional. Suspension mounts in stock location.
- b) Floating hubs permitted. Hubs and axles must be solid steel.
- c) Hardened after-market axles recommended.
- d) Only welded spider gears, full spools, mini spools allowed. No posi-traction units, no lockers and no exotic type differentials. All components must be steel.

19. Brakes

- a) The brake system must use OEM replacement callipers, spindles, hubs and rotors on the front: drums or disc kit on the rear.
- b) Coleman steel hub and rotor replacement may be used in the right and left front.
- c) Brake pedal must be hanging style
- d) Master cylinder must be OEM, mounted on the outside of the firewall in the engine compartment.
- e) No light weight components allowed.
- f) Brake hose and pad material are optional.
- g) Adjustable brake proportioning valves are allowed on the rear brakes only.
- h) No shut off valves or such devices allowed.
- i) Metal/non –burnable air ducts (no fabric or plastic), not larger than 4" in diameter may be used to cool the brakes.
- j) OEM drilled or slotted rotors allowed.
- k) Optionally, the rear drum brakes may be replaced with a "GM Deluxe Metric .810 Rear Disc Brake Kit" consisting of:

- (2) RB-2500 Rotor Bolt Kit
- (2) CB-1150 Weld-on caliper brackets
- (2) BH-3500 Brake rotor hats
- (2) BR-160-0471 .810 rotors
- (4) GM-230-0542 Caliper bolts
- (1) US-7241-9003 Metric caliper
- (1) US-7241-9004 Metric caliper
- Brake pad set of choice

20. Wheels and Tires

- a) **American Racer P/N AR970 (864 compound) on left side. ~~Right Side Tire will be one compound harder than AR970. Part # and compound # TBA.~~** No tire shaving or tire softening agents allowed.
- b) Tires must stay within the confines of the wheel wells, measured at the 3/9 o'clock positions.
- c) **15" Steel wheels** or aftermarket 15" steel wheels with a 3/16" center minimum, welded 360° mandatory. Maximum 8" width allowed
- d) **1" nuts** mandatory on all wheels.
- e) 5/8" wheel studs recommended.
- f) Wheel balancing weights not allowed.
- g) All tires must have their serial numbers registered on the declaration form prior to competing with any tire.
- h) **Total allotment for the 2026 season is a maximum of 12 tires for the regular events based on participation.**
- i) Teams that participate in the first schedule race event for that class will be allowed 6 tires on that day. Teams that fail to attend the first schedule race event will be allowed to use 4 tires at their first event. All teams will be allowed 1 additional tire for every regular race event that they participate in after that.
- j) 4 tires will be allotted for special events (teams MUST qualify and race on these tires during that event to make these tires eligible to be used in your 2026 tire allotment after that special event.)
- k) Tire **cheating** penalty: Penalty for tires that are not declared prior to competition are as follows:
 - i. **Total disqualification from the race in which the penalty occurred. This includes loss of points, prizes, payouts, and flags. Tires used must be added to the car's tire declaration sheet.**
 - ii. ~~The first tire results in the loss of points, prizes, payouts and flags from the race in which the penalty occurred and each additional tire that fails to comply with the tire use rule will result in the loss of 20 points per additional tire to a maximum of 60 points per race in which the penalty occurred.~~

21. Ballast

- a) All ballast **MUST** be securely fastened; minimum of two (2), ½” bolts for every 12 inches of ballast.
- b) Ballast **MUST** painted white with the truck number on it.
- c) All ballast must be mounted no lower than bottom side of frame rail. No ballast behind the rear wheels lower than the bottom of the fuel cell.

22. Safety

- a) **See General Safety Rules**

23. Electronics

- a) No traction control.
- b) No electronic data logging that records any driver performance or chassis dynamics.
- c) No Go-Pro or sport cameras may be used to record any driver performance or chassis dynamics.
- d) Any exotic or unapproved electronics must be submitted for approval 30 days prior to use.
- e) Cell phone use must be approved prior to use.
- f) **Use of two-way radios are optional. Monitoring of race-control channel (Raceceiver) is mandatory.**

Diagrams

Body & Cage Diagram

Roof out sided edge of upper window opening to halo bar.
Maximum distance 5 inches.

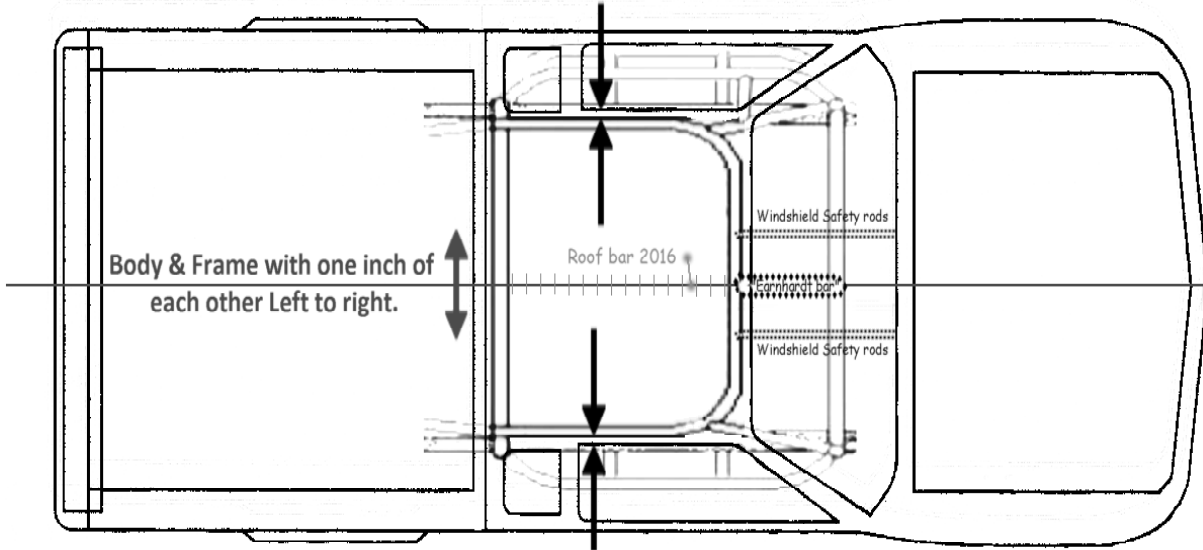

Roof out sided edge of upper window opening to halo bar.
Maximum 12 inch for existing trucks. Desired Maximum distance 5 inches.

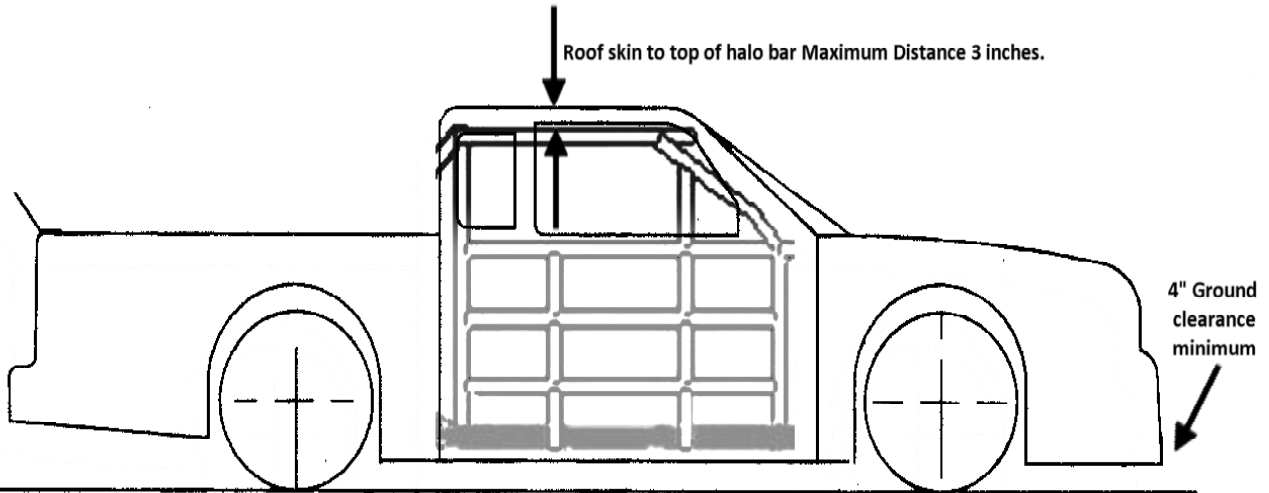

Diagram E:

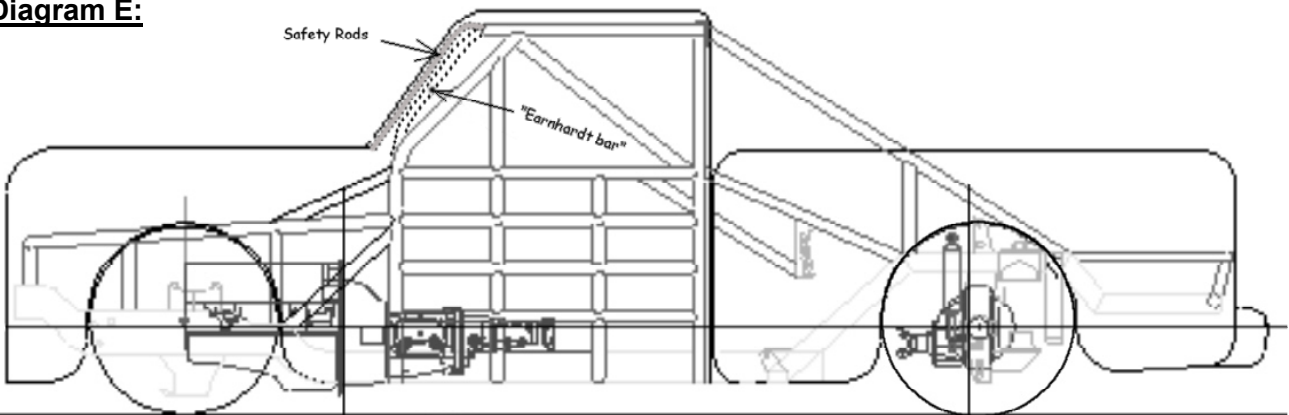

Diagram 1a

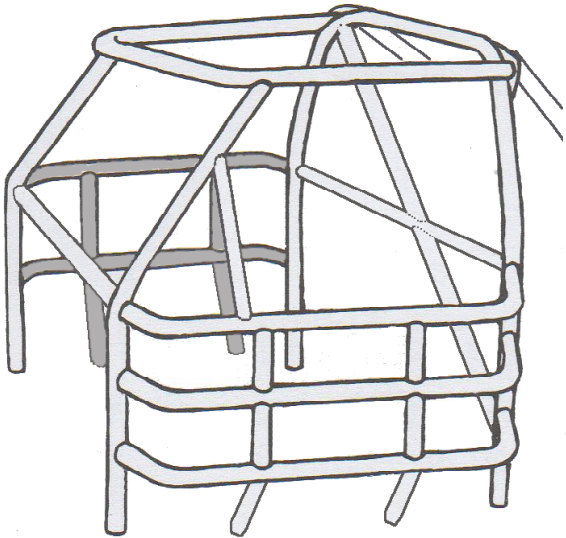

Diagram 1b

Pro-Truck Minimum Rollcage design examples

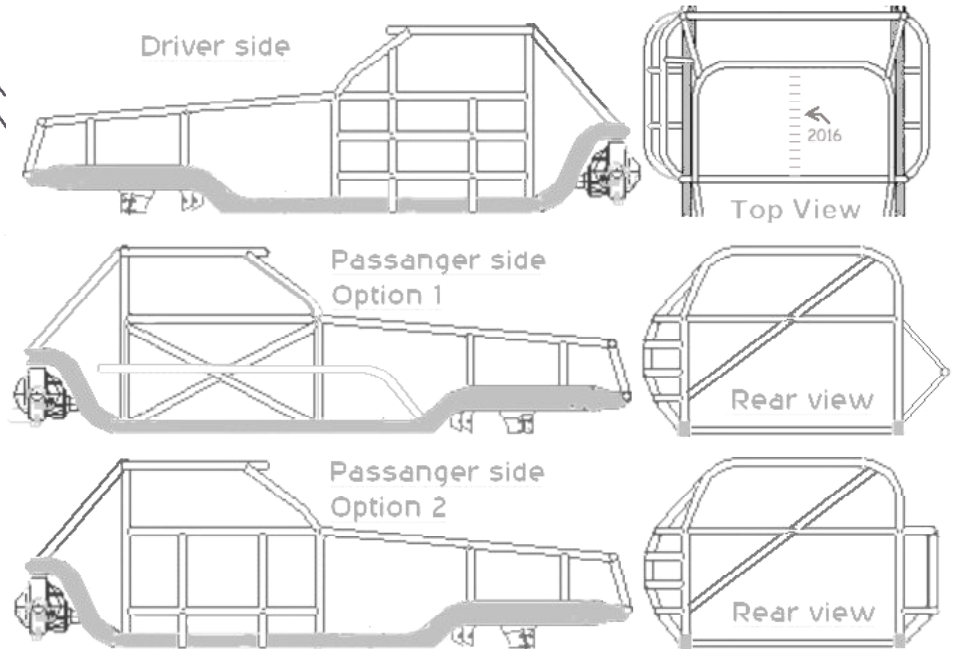

Diagram 2 Fuel Cell mounting & rear frame design example

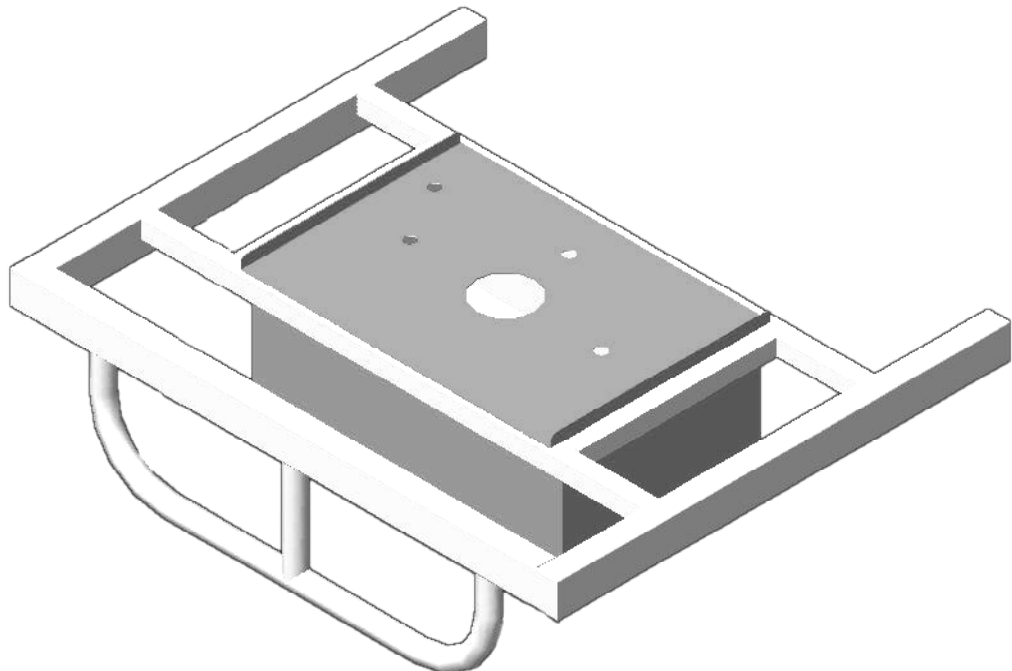
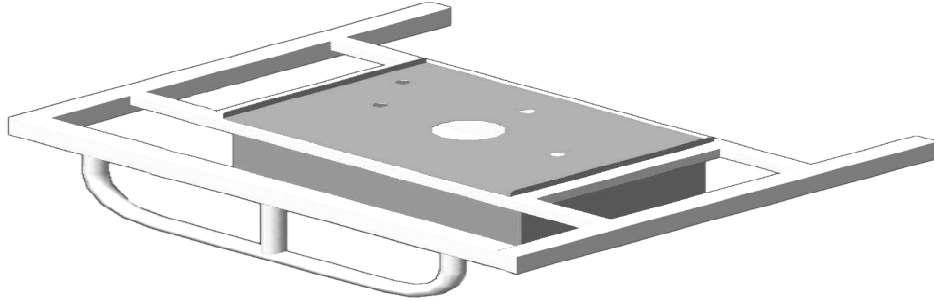

Diagram 3 Drive Shaft Loop examples

TOP view >



ISO view >

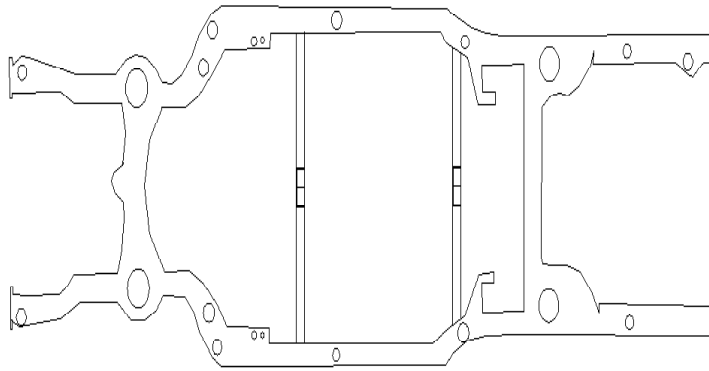
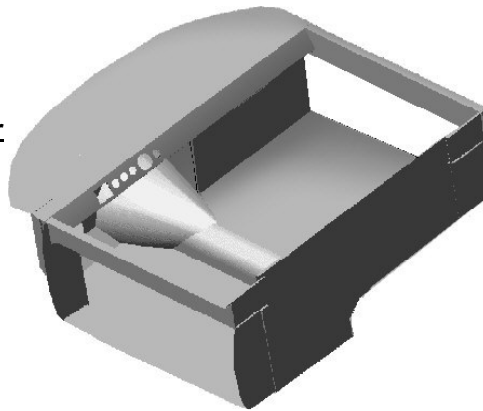
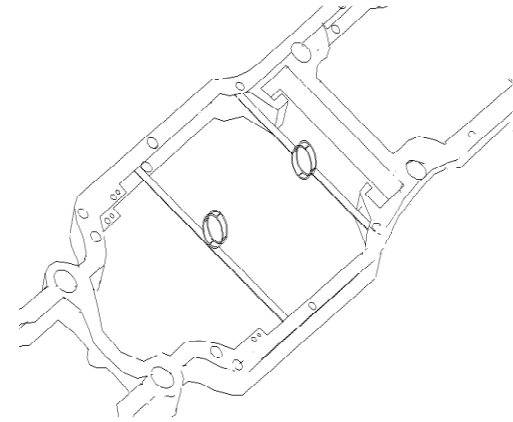

Diagram Interior

Options :



a) Stock style floor & firewall option.



Raised passenger floor set back firewall Option.

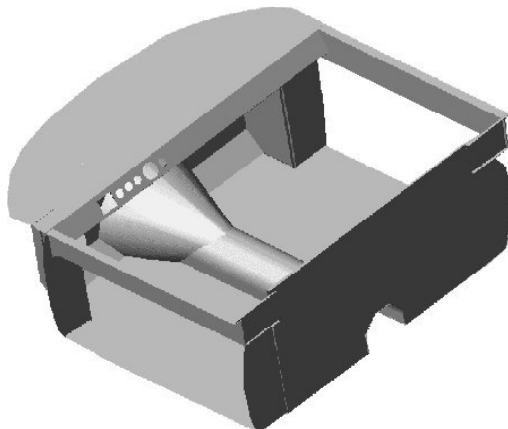

0 -

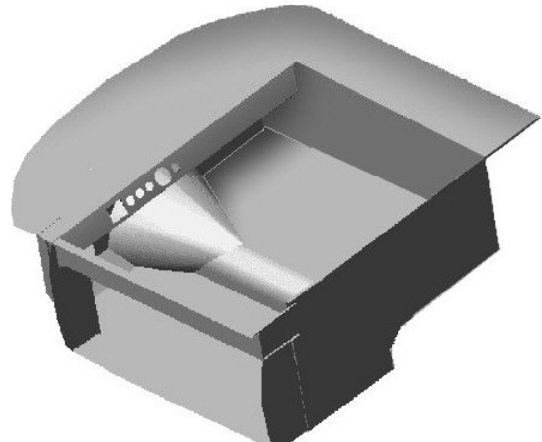

b) *Raised passenger floor Stock style or set back firewall A & B pillar vertical panel options.*

Diagram 5 Exhaust outlets

Can be used on both or one side.

