

2026 RULES AND REGULATIONS

GENERAL RULES & GENERAL SAFETY RULES

Saskatoon Stock Car Racing Association
(S.S.C.R.A)
216-510 Cynthia Street
Saskatoon, SK S7L 7K7
(306) 956-3212



Effective January 2026

MISSION STATEMENT:

“To provide members a motor sports and entertainment facility to showcase their talents and abilities, while providing our fans, corporate partners, sponsors and media a valuable entertainment experience.”

RULEBOOK DISCLAIMER

The rules and/or regulations set forth in this book are designed to provide for the orderly conduct of racing events and to establish minimum acceptable requirements for such events. These rules shall govern the condition of all events, and by participating in these events, all participants are deemed to have complied with these rules. NO EXPRESSED OR IMPLIED WARRANTY OR SAFETY SHALL RESULT FROM THE PUBLICATION OF, OR COMPLIANCE WITH THESE RULES AND/OR REGULATIONS. They are intended as a guide for the conduct of the sport and are in no way a guarantee against injury or death to a participant, spectator or official.

The Competition Director together with Competition Committee, on behalf of S.S.C.R.A., shall be empowered to permit minor deviation from any of the specifications herein or impose any further restrictions that in their opinion do not alter the minimum acceptable requirements. NO EXPRESSED OR IMPLIED WARRANTY OF SAFETY SHALL RESULT FROM SUCH ALTERATIONS OF SPECIFICATIONS. Any interpretation of, or deviation(s) from these rules shall be left to the discretion of the officials. Their decision is final.

Saskatoon Stock Car Racing Association

(S.S.C.R.A.)

Lines with ‘strikeout text’ (strikeout) in RED are rules that have been removed.

Lines highlighted in YELLOW are rules that have been modified this year.

Table of Contents

| | |
|---|----|
| Code Of Ethics..... | 4 |
| General Rules..... | 5 |
| 1. Dress Attire | 5 |
| 2. No Pets Allowed In Pit Area Or On Concourse On Fan Side..... | 5 |
| 3. Back Gate / Pit Entry | 5 |
| 4. Pit Entry – Trailers / Haulers..... | 6 |
| 5. Transponders | 6 |
| 6. Radios / Receivers | 6 |
| 9. Stationary Burnouts..... | 6 |
| 10. Car Numbers | 6 |
| 11. Out-Of-Town And Non-Registered Cars..... | 7 |
| 15. Teams Running Alternate Drivers | 7 |
| 16. Late For Line-Ups | 7 |
| 17. No Working On The Car In The Staging Lane..... | 8 |
| 22. Flags:..... | 8 |
| 28. Post-Race Technical Inspections | 11 |
| 29. Scales..... | 11 |
| 30. Noise Levels | 12 |
| 32. Protest | 12 |
| 33. Sealed Crate Engine Problem..... | 13 |
| S.S.C.R.A. Members Procedures..... | 14 |
| General Safety Rules | 16 |
| Appendix A | 18 |
| Appendix B | 22 |
| Saskatoon Stock Car Racing Association Protest Form | 28 |

CODE OF ETHICS

Purpose

To act in a professional manner so as to bring a positive image to the public and fellow members of the sport of stock car racing and to realize the need for a reasonable and responsible personal code of 'unwritten laws' since laws cannot cover all situations.

Expectations

1. As a member of SSCRA, respect, courtesy and cooperation must be shown to all fellow members, associates, sponsors and guests.
2. In any public setting, present SSCRA, its members and the sport in a positive light at all times.
3. Respect **MUST** be had for all traffic laws and criminal codes.
 - a) No alcohol, drugs, or stimulants allowed in association with your car or team when associated with any stock car event, display or promotion.
 - b) The S.S.C.R.A. reserves the right to ask for medical proof of health for any drivers or individual in the competitors' area.
4. No verbal or physical abuse towards any person when connected with a stock car event, display or promotion or when using social media.
5. All members should be presentable when in any public situation.

Definition of Behavior

1. Anyone who, by word or deed, impedes, jeopardizes, or in any manner hinders the smooth and orderly presentation of the racing program or anyone who commits, or causes to be committed, any detriments to stock car racing, and/or the S.S.C.R.A. will be considered to have abused the privileges of membership or event participation,
2. Entry and/or admission granted by the S.S.C.R.A. and that they may be subject to the revoking of those privileges and/or disqualification as deemed proper by the Executive or designated official.
3. **Drivers are responsible** for the sportsmanlike conduct of anyone in their crew and penalties incurred by a crew member may affect the driver, and or the registered owner.

General Rules

It is the competitor & participants' responsibility to fully understand the General Rules & Safety Rules in addition to the rules that apply specifically to their race division.

Please review the Rules Package applicable to your Division.

1. **DRESS ATTIRE**

- a) No person shall be admitted to the pits unless they are appropriately dressed: shirt with minimum three-inch sleeves, **minimum** knee-length shorts, but full-length pants are recommended.
- b) Closed toe shoes only. (**no sandals or flip-flops**)
- c) Any person dressed improperly, will be asked to dress with proper attire or leave the pits for the remainder of the race meet.
- d) Pit crew and driver clothing **MUST** be clean. Violators are subject to a fine.

2. **NO PETS ALLOWED IN PIT AREA or on Concourse on FAN SIDE.**

3. **BACK GATE / PIT ENTRY**

- a) All people in the competition area **MUST** be members of the S.S.C.R.A. except as provided for visiting members from another club and/or traveling series invited by S.S.C.R.A.
- b) All persons entering the competition area including officials **MUST** sign a release waiver.
- c) Anyone under 18 entering the pit area **MUST** have parent's written permission to enter pit area during competition.
- d) No one under the age of 12 years is allowed in the pit area during competition unless registered as a Bandolero driver.
- e) BANDOLERO participants will be permitted entry to the pits at 8 years of age. Actions and behaviour of junior members will be monitored. Parental Waiver required with BOTH parents signature for all individuals under age 18. Pit entry privileges may be revoked if warranted.
- f) SSCRA reserves the right to limit pit entry to **eight** people, including the driver, with each car/truck per race night.
- g) Entry to the pits will be granted once the **back gate fee has been paid and waiver signed.**
- h) **NO Season Tickets, NO Flex Tickets** or other promotional tickets will be accepted at the back gate entrance.
- i) Back Gate will be closed at one hour before the scheduled start time on that given event. Once gate is closed, pit crews or drivers must enter from Fan Side. **See Fan Side Manager for entrance and signing of waiver.**
- j) It is the driver's responsibility to inform their crew of the rules and regulations. Fines will be levied against the car/truck driver/owner.
- k) While a race is in progress, **NO ONE** will cross the track.
- l) Drivers without a valid driver's license may apply to the Executive for approval to compete. Anyone under 18 years of age **MUST** have both his/her parents' written

permission to race. If a driver's license is revoked, only the S.S.C.R.A. Executive can make reinstatement to race.

4. PIT ENTRY – TRAILERS / HAULERS

- a) Cars will not be allowed to compete unless they are hauled/towed to and from the track.
- b) Race cars **MUST** be unloaded in the pits / competitors parking before the back gate closing time scheduled on race day.
- c) All race cars must remain in the pit area until **30 minutes after** the final race of the program has finished **to permit fan interaction**. Cars may enter and leave at other times by permission of the Competition Director or the appointed official only.
- d) Division pit stalls and parking areas will be appointed and laid out in race day schedule. Exception at discretion of Competition Committee to accommodate duo division teams.

5. TRANSPONDERS

- a) All cars/trucks in competition will be provided a transponder by SSCRA for a rental fee. Transponder rental fees will be paid at the back gate but **with the transponder** provided at the tech booth each race day.
- b) Rental transponders must be returned at the end of each race meet **to the tech booth**. Drivers will be responsible for any lost or damaged transponder.
 - i. Transponders **not returned** after evenings race program will result in a possible penalty or full replacement cost of transponder.
- c) Mounting location will be determined by Tech Committee.

6. RADIOS / RACECEIVERS

- a) RaceCeivers are mandatory in all divisions and must be working at all times when car is on track.
- b) In divisions which radios **are allowed**, either spotter or driver must have the capability of receiving this said given frequency at any given time. Spotter with this device must have direct communication with their driver.
- c) In Divisions where radio communication is allowed, only one spotter that is in radio contact with a car currently racing will be allowed on an elevated platform in the pits and/or one on the tower.
- d) If the spotter does not relay the information to the driver or the driver doesn't respond in a timely manner the car will not be scored.
- e) Any platform that is more than 24 inches above ground level must have a 42-inch high guard rail on all sides. Only properly designed platforms will be allowed. i.e. no standing on tires, chairs, etc.

7. **No vehicles**, other than the cars competing and track service vehicles, will be allowed in the pit area during competition.

8. **Cars left in the pits** over 24 hours will be considered abandoned and become property of the S.S.C.R.A. Unless permission from Competition Committee or appointed official.

9. **Stationary burnouts** on the race surface will result in a minimum **\$125.00 fine**.

10. Car Numbers

- a) All numbers are assigned and are property of the S.S.C.R.A.

- b) Car numbers will be limited to a maximum of two digits, a third digit or letter maybe used with permission from the Competition director or the appointed official.
- c) Numbers must be clearly legible and **Must** appear on both sides and roof and side numbers must be located no higher than top of door
- d) **Minimum 18" high x 18" wide with a four (4) inch stroke.**
- e) **Must** appear on the left head light and right taillight of car at least 4" tall.
- f) If a number cannot be read from the main tower to the back straight, it will have to be changed.

If a current member has a number for that year, they retain that number next year, providing they register their car by opening day. or if they miss the next year, they may have that year as a grace period. If they return the following year prior to race season opener with a registered car they would retain the number. If not, they lose rights to it.

11. **Out-of-town and non-registered cars MUST** change their car number for that specific race day if their number conflicts with a local car number.
12. The top portion of the windshield in all divisions is reserved by the SSCRA for club and/or division **sponsorship banners**. No marking or decals are to appear below the banner. Teams must use the supplied decal unaltered.
13. All cars competing, whether from different tracks or previous years, **MUST** comply with the current S.S.C.R.A. rules to receive local points and/or payouts/prizes/feature flag.
14. **Visiting cars DO NOT receive local points.**
15. **Teams running alternate drivers during a race day MUST advise the back gate and the Competition Committee or his designated official as to who is running which heats and the feature race.** Alternate driver must be named on Registration Form.
 - a) Any driver change, other than named alternative, must start at back of the pack but will maintain points. Named alternative drivers maintain their position.
 - b) **Driver changes at the track** during the event may occur going up, down, or within a division as long as the race director gives permission.
 - c) The car **MUST** start at the rear of the lineup for the remainder of the event. All points go to the registered driver/car combination; last place points will be awarded.
 - d) In case of medical reasons or a scheduled absence, Competition director or the designated official may approve a replacement driver with points going to the registered driver/car combination.
 - e) Line up and positioning for qualifying and/or races is the responsibility of each race team; knowing which race and what position to be in rests with each car's crew.
16. Drivers are only permitted to compete in one race car per class per event. Swapping numbers, renting, buying, or spare cars will not be permitted to compete after the start of the first heat race. **Drivers are not permitted to move down in classes without permission from the Race Director or the Competition Committee.**
17. **LINE UPS:** Rookie drivers will be required to start from the tail of the field for their first two race events. The officials may, at their discretion, place racers at the tail of the field based on the racer's habitual performance. Examples of this include, but are not limited to, the racers

inability to maintain a sufficient pace on starts to avoid creating unsafe racing conditions, lack of car control, or any other factor that in the opinion of the officials will create unsafe conditions or impede the running of a race in a timely fashion.

18. **ROOKIE RULE:** You are allowed to run a maximum of two races in one year without having to qualify for rookie status. On your third race or second year of competition, you automatically qualify as a rookie.
19. **Late for line-ups:** Any car late for a lineup will be placed at the back of the lineup. Exceptions are at the Competition Director or appointed official's discretion only.
20. **POINTS FINAL ELIGIBILITY:** Cars that have not run at least once prior to the points final in that year are not permitted to compete. Must be locally registered and must run local rules. Line ups shall be determined based on attendance at prior events that year. Teams that competed in 100% of the prior races that year will be lined up at the front. These cars may be lined up based on points, qualifying, inversion, etc. based on the format chosen by the Competition Director. Furthermore, other cars may be lined up based on their attendance record and/or points.
21. **No working on the car in the staging lane.**
 - a) One crew member allowed per car/truck in the staging lane. Crew member to remain positioned at the left side of the car/truck.
 - b) ~~Other exceptions only at the Race Director's or Competition Director or appointed official's discretion, including refueling.~~
 - c) ~~Only Pro Late Model / Super Trucks~~ All divisions will be allowed to adjust tire pressures prior to entering the racetrack. Portable air tanks & air pressure gauges only will be allowed on staging lane. No jacks.
 - d) Anyone holding up advancement in pre-staging will be put to the rear of the field.
22. Some races may be designated as using the staging lane as 'hot pits'. The hot pits are separated from the main pits by the concrete barrier. No crew member may go over the barrier into the hot pit until their **car has come to a complete stop. No more than three crew members in the hot pit at any time.** The car may not leave the hot pit until all their crew members are back over the barrier.
23. The Competition Committee will make up race day schedules and reserves the right to alter the race schedule during the event to accommodate unforeseen circumstances.
24. The Race Director, Flagman, and Race Officials are in complete charge of the races. They have the authority to disqualify and/or penalize any cars obstructing the race as they see fit.
25. The **Start/Finish line** will be the center of the front straight.
26. **Flags:**
 - a) Any disregarding of the flags will result in a penalty, fine and/or suspension.
 - b) **Race "go" line zone on flag drop** is from yellow line on track in corner four (4) to start/finish line. The race is started when flagman throws green flag.
 - c) **Green:** The waving of the green flag signals the start of the race. A rolled up green flag displayed during warm up laps indicates the race will start on the next lap (green light).

- i. **Rolled up one to go means green next lap, no exception. In the event of a 'jump start' the green flag flies, caution flag will be thrown the next lap and then a complete restart takes place**
 - ii. **All cars must take the green flag to be scored in that race. Cars that do not make it for the start of any race must get clearance from the Race Director or Pit Marshall before being allowed to enter the track during that race.**
 - iii. **All cars must maintain pace vehicle speed on a start or on a restart. If the car pacing the start slows excessively, that car will be penalized on the first green lap. We will use a radar gun to monitor pace speed and if the car pacing the restart or start slows below a determined limit, that car will be black flagged on the lap following the start or the restart. The car will travel through the pits to the pit exit observing our pit speed (5mph/8kmph) and will rejoin the race when our pit exit official determines it is safe (you will get the go sign.)**
- d) **Yellow**: CAUTION – Indicates an incident has occurred that is a hazard to the cars/drivers in the race (yellow light).
- i. The caution flag will be given to the first car passing under the flagman.
 - ii. Restarts are determined by the last completed green flag lap; restart lap is started by position one.
 - iii. The officials may choose to put one or more of the cars to the back based on their determination of who was at fault for the caution. Furthermore, the officials may choose to return a competitor or competitors to their pre-caution position based on their determination of fault with a competitor. In the event that no determination of fault can be ascertained, all parties involved in the caution will be put to the back. The flagman and/or his assistant and officials will make the decisions on all of these matters.
 - iv. Cars pitting while the race is under caution will rejoin the field at the rear.
- e) **Red**: Indicates drivers are to stop even with and to the right of the flagman displaying the red flag (red light).
- i. No car may enter the track while the track is under red.
 - ii. Work can continue on any vehicle already in the pits prior to red flag.
 - iii. Work can commence on any vehicle entering the pits while the track is under a red flag condition.
 - iv. Once the red flag is lifted and track goes to caution the vehicle may enter the track under official's direction.
- f) **Black**:
- i. A rolled up black flag pointed at any car during a race serves as a warning that an infraction of the race rules has occurred.
 - ii. An open black flag directed at any car means the car must immediately leave the race and report to Staging Lanes at Start/Finish Line. The Infield Official under

direction from the flag man will give explanation of penalty; you may be instructed to go to the back of the field or parked for that race.

- iii. For all open black flags, your car number will be flashing on the scoreboard. You have three laps to leave the track and report to the Competition Director*. After three laps disqualification from the race is automatic and you will no longer be scored for the balance of the race.
 - iv. If you receive 3 open black flags for that race event you will be disqualified for the remainder of that race event.
 - v. Any car disqualified from a race will start at the back of the pack for the balance of the race event or the first race of the following race event if disqualification was in the feature.
- g) **Black with yellow dot:** Indicates a mechanical or structural problem with your car that is a hazard to yourself or other cars in the race.
- i. You must immediately report to your pit to have the problem corrected.
 - ii. The car may not re-enter the race until cleared by your division's technical inspector or a race official.
 - i. Your car number will be flashing on the scoreboard. You have three laps to leave the track. After three laps, disqualification from the race is automatic and you will no longer be scored for the balance of the race.
- h) **Blue:**
- i. Indicates you are being lapped and must hold your race line; **either high or low**, permitting cars to pass uninhibited.
 - ii. You may also be blue flagged if your are purposely blocking or obstructing cars from passing. If you disregard the blue flag; under discretion of the flag person you may be black flagged.
- i) **White:** Is displayed to the leading car and indicates one lap remains in the race.
- j) **Checkered:** Is displayed to the leading car and indicates the race is complete.
- i. If you are running under a caution flag, you **MUST** get the green, white and checkered flags, before the race is complete; not to exceed two (2) attempts.

23. 'First lap' caution

- a) In the event a caution is necessary before the first lap is complete, there will be a restart based on the original starting lineup.
- b) First false start the offender will maintain his original starting position; second false start by the same individual the offender will be sent to back of the field.

24. A **race is deemed complete** after 50 percent of the scheduled laps have been completed if a race needs to be halted before race length is completed. *i.e. rain or in excess of allotted time limit*

25. A penalty of \$50.00 will be issued to anyone who inquires about race results before posting. Any attempt to destroy or impair tower official's capacity for collected thought or decisive action will result in a \$50.00 fine.

26. Technical Inspections: Omission of any technical/mechanical rule does not imply it is legal.

- a) ALL cars competing **MUST** go through tech inspection **BEFORE RACING**.
- b) S.S.C.R.A. registered cars/trucks **MUST** be checked on designated tech days, otherwise a \$100.00 fee will be charged for a non-scheduled tech inspection.
- c) No initial teching will be performed on race night for non-teched cars, unless prior arrangements are made with the Competition Committee or the division tech.
- d) The driver/owner of the car is responsible to make their car conform to S.S.C.R.A. rules.
- e) All Tech equipment that is owned and used by the S.S.C.R.A. Competition Committee will be considered FINAL. No protests will be accepted!
- f) No unkept cars allowed. In the interest of maintaining a professional image with our fans and sponsors, we require cars to be presentable. Car must have a reasonable appearance and decaling. The technical officials will use their discretion when enforcing this rule.

27. If you have a tech problem not specified in the rulebook, contact the Competition Committee for your division and receive a written opinion.

28. Post-Race Technical Inspections

- a) Top 3 in a Club Event **MUST** go to tech line or disqualification will be automatic. Top 5 **MUST** go to tech at Special Events
- b) Anyone waved to tech line after race, **MUST** go directly to the tech area, or disqualification will be automatic.
- c) All illegal parts will be confiscated ~~and become property of S.S.C.R.A.~~ **to be returned at end of race season.**
- d) Refusal to comply with tech will result in immediate suspension of the car and number for the remainder of the year.
- e) Tire Penalty: Penalty for tires that are not declared prior to competition are as follows:
Total disqualification from the race in which the penalty occurred. This includes loss of points, prizes, payouts, and flags. **The tires used must be added to the car's tire allotment sheet.**
 - ~~ii—The first tire results in the loss of points, prizes, payouts and flags from the race in which the penalty occurred and each additional tire that fails to comply with the tire use rule will result in the loss of 20 points per additional tire to a maximum of 60 points per race in which the penalty occurred.~~

29. Scales

The scales owned by the S.S.C.R.A. when used in the locations permanently ~~marked on the inspection pad~~ **installed in the Jim Christie Tech Lane** at Sutherland Automotive Speedway are the benchmark and will determine the actual weight and weight percentages of all cars.

- a) Any car that fails the weight and/or measurement requirements for their division, **or found with non-conforming (illegal) parts,** will lose any points and/or prizes / feature flag / money earned for the race where the infraction occurs.
- ~~b) If a car is found to be illegal, that car will lose the points and any prizes / feature flag / money earned at that race meet. plus 15% of the total points to date.~~

- c) For a second offense, the car will be penalized as above and additionally receive a ~~two~~ **one** race meet suspension

30. Noise Levels

- a) It must be recognized that ~~Wyant Group Speedway~~ **Sutherland Automotive Speedway** is in a jurisdiction that has a **noise bylaw**. Procedures will be in place to conform with these laws.
- b) All cars/trucks competing **must have a muffler** and will be subject to a maximum noise level of 98 decibels.
- c) Cars that fail to meet the maximum noise level will be required to install spec mufflers or muffler prior to the next event. Part numbers to be determined.
- d) ~~All cars will be required to run spec mufflers or muffler in 2022~~
- e) Decibel readings will be taken in the pits and stands at a designated location with a decibel meter owned by the S.S.C.R.A. to insure conformity to the by-law.
- f) This meter will be the standard for all cars/trucks.
- g) Cars/trucks not meeting the standard will have one race to meet standard. If no action is taken to conform to the rule, the offending car will not be allowed to compete until correction is made.
- h) The Race Director can shorten scheduled races that extend beyond a reasonable time to ensure all racing is complete by 10:00pm, unless an extension has been specifically granted by the RM for that date.

31. The SSCRA Competition Committee reserves the right, in the Spirit of Competition, to add devices to any vehicle to equal competition.

32. Protest

- a) A car driver **or owner** may file a protest against a single car within their division. Only one car protest per team per race event is allowed.
- b) All protests (relating to teching or finishing positions) **MUST** be submitted to the Competition Committee or designated official within 30 minutes of the conclusion of the final race of that day.
- c) Protests **MUST** be submitted on the official protest form available from the competition committee. All protests to be written, signed by the driver **or owner**, and accompanied by the required fee (cash).
- d) Competition Committee will rule on the protest by the Wednesday following the protest.
- e) The fees will run as follows:
 - i. ~~\$200~~ **\$300** Chassis and suspension inspection ~~or, Cylinder head, intake, camshaft, exhaust, and carburetor (top end) inspection~~ **or**, clutch, transmission and differential ratio inspection.
 - ii. **\$2,000** **Cylinder head, intake, camshaft, exhaust and carburetor (top end) inspection.**
 - iii. ~~\$300~~ **\$2,500** Cylinder head, intake, camshaft, exhaust, carburetor, oil pan, one connecting rod, piston and crankshaft **(bottom end) inspection.**

- iv. ~~\$350~~ \$1,250 Dyno test of horsepower only of a sealed crate engine in applicable divisions. ~~This is a service only and no monies will change hands whatever the outcome of the test result is. Monies are non-refundable!~~ \$1,000 will be paid to the Dyno Shop and is non-refundable. If the engine is found within specifications, \$250 will be awarded to the car owner for shop supplies. If the engine is found not in compliance with specifications, \$250 will be returned to the person who filed the protest.
- f) ~~There **MUST** be one spokesperson from the protesting car present during any dispute or tear down of the vehicle.~~ Only the person who filed/paid for the protest may be present for any teardown. No third-party representatives.
- g) All protests requiring teardown will be subject to a Competition Committee surcharge of \$250.

33. In the event of a sealed crate engine problem, the following procedure will be enforced.

- a) A **supervised** engine inspection will be performed by a member of the Competition Committee. The installation of engine components must be supervised and **SSCRA seals** will be installed. **ALL components must be Genuine to the Manufacturer specifications for that engine and proof of component part numbers must be provided to the inspector.** In the event of “any” machining must be done (resurfacing block or cylinder head), the engine part must be replaced. **All costs of travel** for the inspector will be covered by the individual who requests this service.

34. For Compliance procedures refer to SSCRA Crate Engine Registration.

35. Car Count Policy

- a) In order to provide our spectators with an entertaining show, we require there to be 8 cars minimum in each division racing.
- b) When a division does not meet the 8 car minimum standard, the Executive and the Competition Committee will progressively intervene with the goal of working with race teams to achieve a minimum of 8 cars in the division.
- c) If a division’s car count remains at 6 or 7 for a full season, there will need to be a plan and guaranteed registrations to continue racing in the following season.
- d) When a division has only 5 cars, we will allow them to race a single race day, but will require all racers to work with the Executive and the Competition Committee to create a plan to guarantee that the car count would be at an acceptable level to continue to race for the remainder of the season.
- e) When a division has less than 5 cars, they will not be permitted to race.

S.S.C.R.A. Members Procedures

1. Track Record.

- a. Permission MUST be granted one week prior to an attempt to set a track record. The time trial will be held one half hour prior to the race event start time.
- b. The car/truck must immediately report to tech following the record attempt. If a track record is set during scheduled time trials, the cars/truck will be waved to tech.
- c. No track record will be awarded until the car/truck passes technical inspection.

2. Displays:

- a. Any displays involving more than one member and car MUST have the approval of the S.S.C.R.A. Executive or the Advertising and Promotions Committee.
- b. No one is allowed to use the Bridge City Speedway Inc., Sutherland Automotive Speedway ~~Wyant Group Speedway~~ or S.S.C.R.A. credentials, which are the property of the S.S.C.R.A., without the permission of the S.S.C.R.A. Executive.
- c. Any violation of this rule may result in suspension.

3. Trophy / Awards:

a. "Rookie of the Year":

- i. Rookie of the year trophy will be awarded to the eligible driver who has the most points and who has raced a minimum of 80% of that year's race.
- ii. Rookie status drivers can move upward in divisions from Bandolero to Run Your Junk to Street Stock to Pro Truck to Super Stock to Super Late Model, but cannot move down.
- iii. Rookies MUST register on driver's application forms at the start of the year so executive can review qualifications.
- iv. If anyone other than the registered rookie driver races the car during the year, the race director MUST be informed and rookie points will be forfeited for that race, car points remain.
- v. Rookie Drivers must run Yellow Rookie Stripe on rear bumper.

b. "Most Improved Driver", "Best Looking Car & Crew", and "Most Courteous Driver" ~~and "Phoenix Award"~~ will be voted on by the drivers in each division by ballot.

4. In the event of behavior unbecoming of an S.S.C.R.A. member (not complying with the Associations' set Code of Ethics), the Executive will review the privilege of membership. The Executive will decide if censure, written warning, probation, suspension, or revocation of membership is to follow.

- a. Any actions felt to be intentional to harm a competitor's car in non-competition will result in suspension and/or fine.
- b. Any action felt to be intentional to harm a fellow member will result in either expulsion, suspension and/or a fine.

- c. Any verbal or physical altercations in the public eye will result in suspension and/or a fine.
5. **Swearing, abusive or ungentlemanly conduct towards or any Association official is subject to an immediate suspension of two race meets and/or a fine. Any physical contact will bring an automatic one-year suspension from the S.S.C.R.A. from the date of the offense. All S.S.C.R.A. members are responsible for their own fines and the fine is to be paid before the next race day or the offender will be refused pit entrance.**
 6. ALL persons in the competitor area are not to be under the influence of or in the possession of stimulants, illegal drugs or alcohol proceeding, during or after a race. Offenders will be suspended for two race meets for the first offense and for the remainder of the season for the second offense. Breathalyzer and urine samples may be requested and refusal to comply will result in a three race meet suspension.
 7. All rulings made by the S.S.C.R.A. Executive are final. If one of the Executive is being protested, they **MUST** step down while the matter is handled by the rest of the Executive.
 8. Notice of infraction of any of the rules may be issued by any Race Official. Where provided, fines and/or discipline is automatic. Where a fine or discipline is not defined in these rules, the matter will be decided by the Competition Committee or the ~~Ethics Committee~~ **Executive** as appropriate.
 9. **The right of appeal** is given to any member of the S.S.C.R.A. who has been disciplined for any infraction of rules, regulations, or specifications of the S.S.C.R.A. with the exception of a black flag.
 10. The appeal must be filed in writing by the Wednesday following the notice of discipline. The appeal will be heard **by the Executive at their earliest convenience.** ~~next Wednesday and a decision rendered before the next race meet. The Appeal Committee will consist of the President, the First Vice-President and the Second Vice-President. The Appeal Committee shall select a Director to act as an alternate in the event one of the above must stand down due to a conflict of interest.~~
 11. **All cars/trucks MUST** provide at least one representative for opening and closing work parties and as scheduled by the director of volunteers.

General Safety Rules

1. **Fire Extinguisher (car):** **Not Allowed** ~~Optional: every car may have a 2.5lb (1kg) fire extinguisher with a recharge slip back dated no more than 12 months. The extinguisher **MUST** be mounted securely with a metal quick release mechanism or fire system release cables mounted within reach of the driver with seat belts fastened.~~
2. **Fire Extinguisher (pit):** Every car **MUST** have a 5lb (2.5kg) fire extinguisher with a recharge slip back-dated no more than 12 months accessible in the pit area.
3. Only left-hand drive vehicles may participate in race events. Racing shall take place in a counter-clockwise direction only on the track.
4. All bars and components that the driver's head or limbs may come in contact with **MUST** be **padded** with a suitable crushable material. No water pipe insulation. The steering wheel center, including OEM steering wheels, **MUST** be padded with a minimum of 2" of approved crushable material.
5. **Automatic Transmission:** Any car in any division with an automatic transmission **MUST** have a neutral safety switch, which may be routed through the brake light switch.
6. **SFI approved oval track aluminum racing bucket seat** with head support, properly mounted to the roll cage is mandatory **in all divisions**. ~~Aluminum.~~
7. **Seat Belt**
 - a) Every car **MUST** be equipped with a 5-point quick release seat belt. Shoulder mounts **MUST** be mounted level with the shoulder to four inches below shoulder and in accordance with manufacturer's instructions. Seat belts to be anchored to the seat mount and/or roll cage at a 45-degree angle with reference to the floor of the car. Crotch strap to go through the seat and anchor behind the driver's chest line. All belts **MUST** be mounted to the seat mount and/or roll cage. See diagrams C1, C2, C3, C4, and C5.
 - b) Minimum 2" wide belts are mandatory in all divisions. All belts **MUST** be clearly labeled and dated by the manufacturer. Systems **MUST** be updated at **4-year 5-year** intervals from the date of manufacture in ~~Pro Late Model division and Sportsman, 5-year intervals~~ **in all other divisions, except Run-Your-Junk, which will be limited to 8-year intervals.**
 - c) Seat belts will have to be changed prior to the prescribed frequency if they exhibit wear or fraying **or excessive sun damage** of the fabric.
 - d) Seat belts must be worn at all times on the track.
8. **Window Net:** Every car **MUST** be a quick opening type from an approved manufacturer, equipped with a **TIGHT** driver's side window net. Net **MUST** be web style and quick opening, complete with mounting rods composed of minimum 3/8" steel rod. Attaching points **MUST** be of equivalent strength and mounted to roll cage. Window nets must be 'up' at all times on the track.
 - a) ~~Mini Stock: Passenger side window protection **mandatory**, device may be a quick release similar to driver's side window net to allow access for safety crew. Push button type release may also be used on passenger side subject to discretion and approval of Competition Committee.~~
9. **Racing Suit:** All drivers **MUST** wear a minimum single layer SFI certified racing suit. Super Late Model and **Super Stock** drivers **MUST** wear a two-layer SFI certified racing suit. A single layer certified racing suit with full Nomex underwear is acceptable as two layers. Racing suits

exhibiting excessive wear or abuse must be replaced. To avoid contamination of safety gear, the driver shall not handle gasoline or flammable products while wearing any of their fire-retardant racing gear.

10. **Helmets** for all divisions **MUST** meet Snell ~~SA2015~~ SA2020 or newer specifications or equivalent. Half-shell helmets are not permitted. Full face, Snell Automotive Sports (SA) design helmets are recommended. Fire retardant balaclava recommended.
11. **Mass produced head and neck restraint systems mandatory** in all divisions. A neck collar does not qualify as a head and neck restraint system. ~~Exception: for the Enduro and Street Stock Invitational the minimum requirement will be a neck collar.~~ Must be SFI certified
12. **Eye protection mandatory in all divisions.**
13. **SFI fire retardant driving gloves are mandatory in all divisions.**
14. **SFI certified racing shoes are mandatory in all divisions.**
15. **No Lithium batteries.**
16. **Electronics**
 - a) No traction control.
 - b) No electronic data logging that records any driver performance or chassis dynamics.
 - c) No Go-Pro or sport cameras may be used to record any driver performance or chassis dynamics.
 - d) Any exotic or unapproved electronics must be submitted for approval 30 days prior to use.
 - e) Cell phone use must be approved prior to use.
17. Any protective gear exhibiting excessive wear, holes or abuse must be replaced.
18. **Lights (Optional):** Brake lights are not permitted.
19. No rear **window louvers** allowed. Front and rear windows must be unobstructed and kept clean.
20. When a collision or rollover occurs, **ONLY THE SAFETY CREW WILL BE ALLOWED NEAR THE CAR.** The ambulance crew or first aid attendants will first determine whether to remove the driver from the car before righting it. (There is a chance of serious injury to the driver when being removed if internally injured.) The tow truck will move the car to right it. All drivers in competition **MUST** remain in their cars until the race is completely stopped. Anyone finding that for any reason he/she cannot continue to race should leave the racing surface to avoid jeopardizing themselves or other competitors.
21. The officials or the flagman may disqualify cars containing loose objects or any other items that could be a detriment to other competitors.
22. **Speed limit** in the pit area, including the staging area, is 5 mph (8 kmph). No excessive wheel spinning. Violators are subject to a fine.
23. Any safety violation will result in a one-race meet suspension and/or fine, pending discretion of Competition Committee.

Appendix A

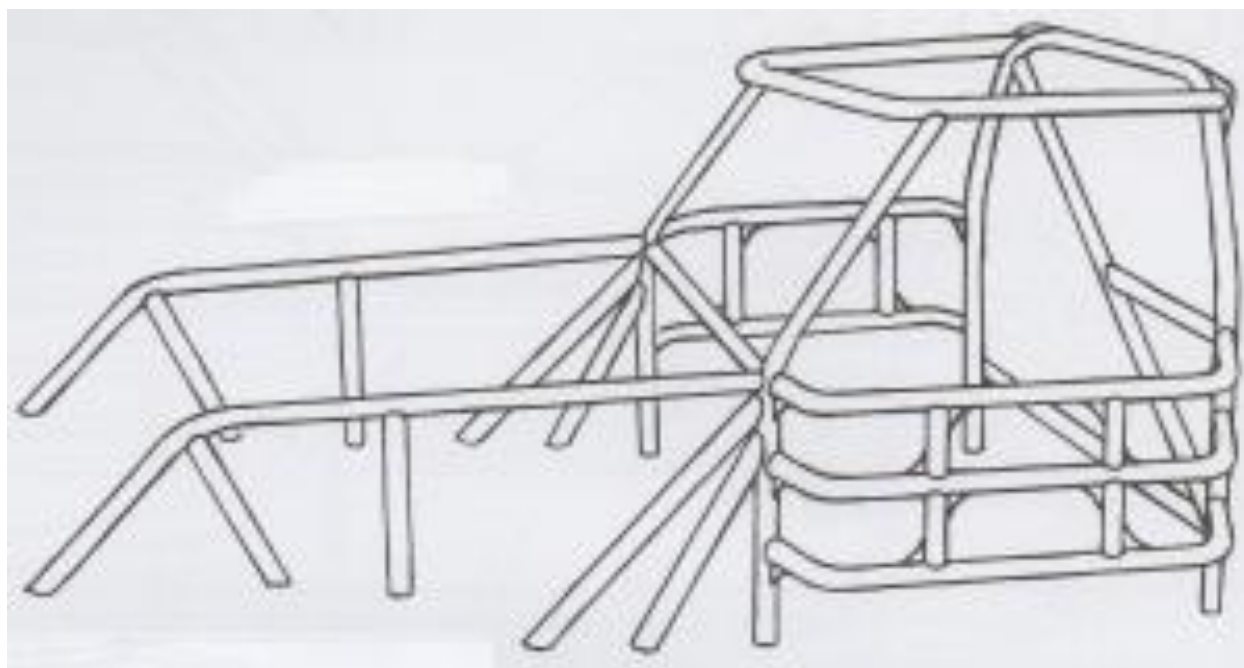

Diagram 1A

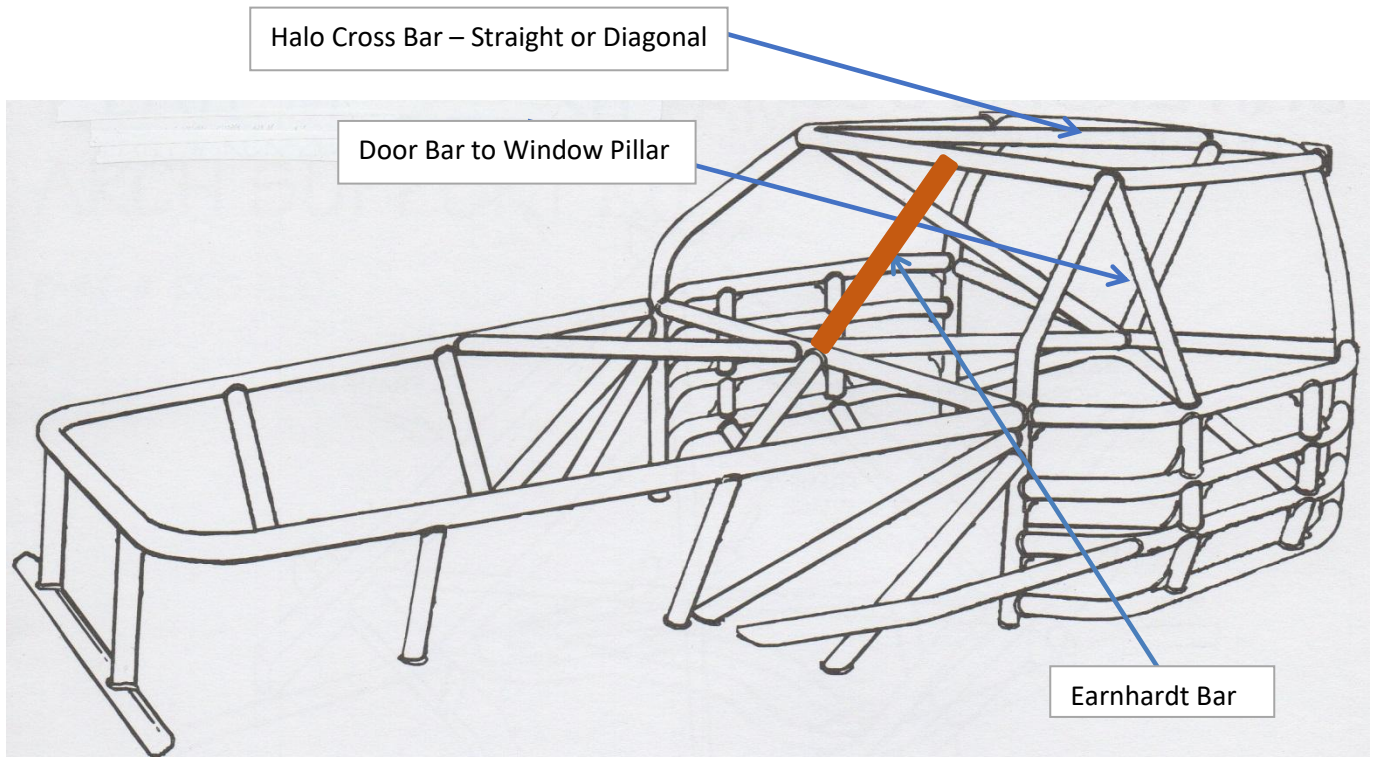

Diagram 2A

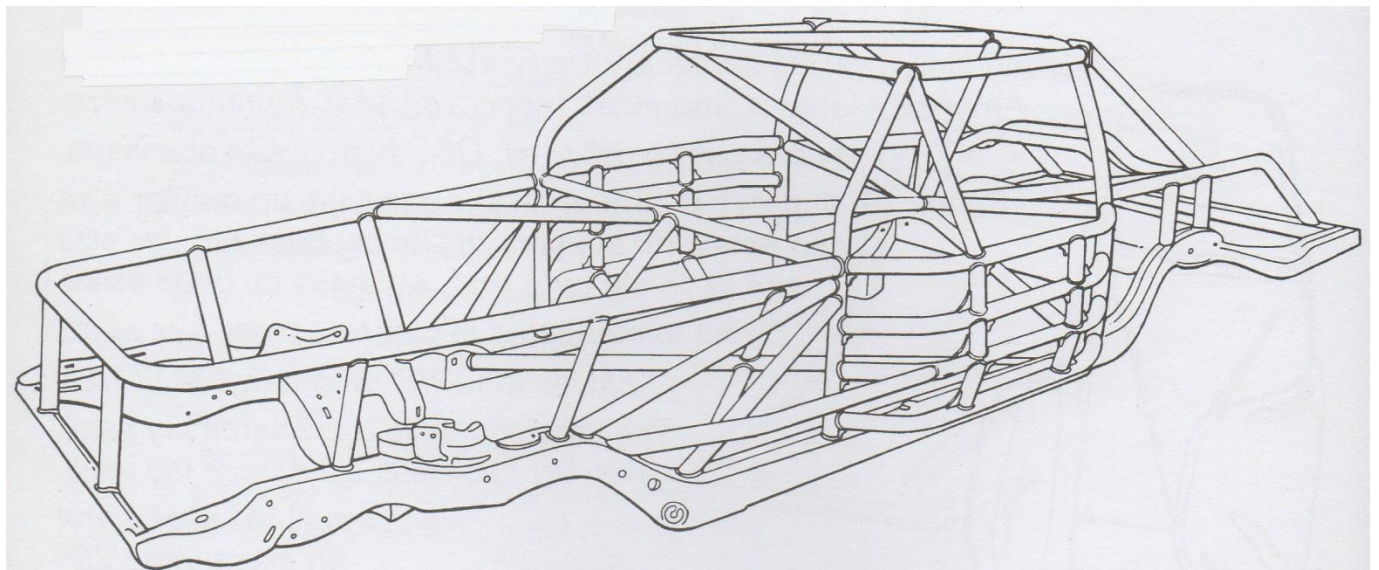

Diagram 3A

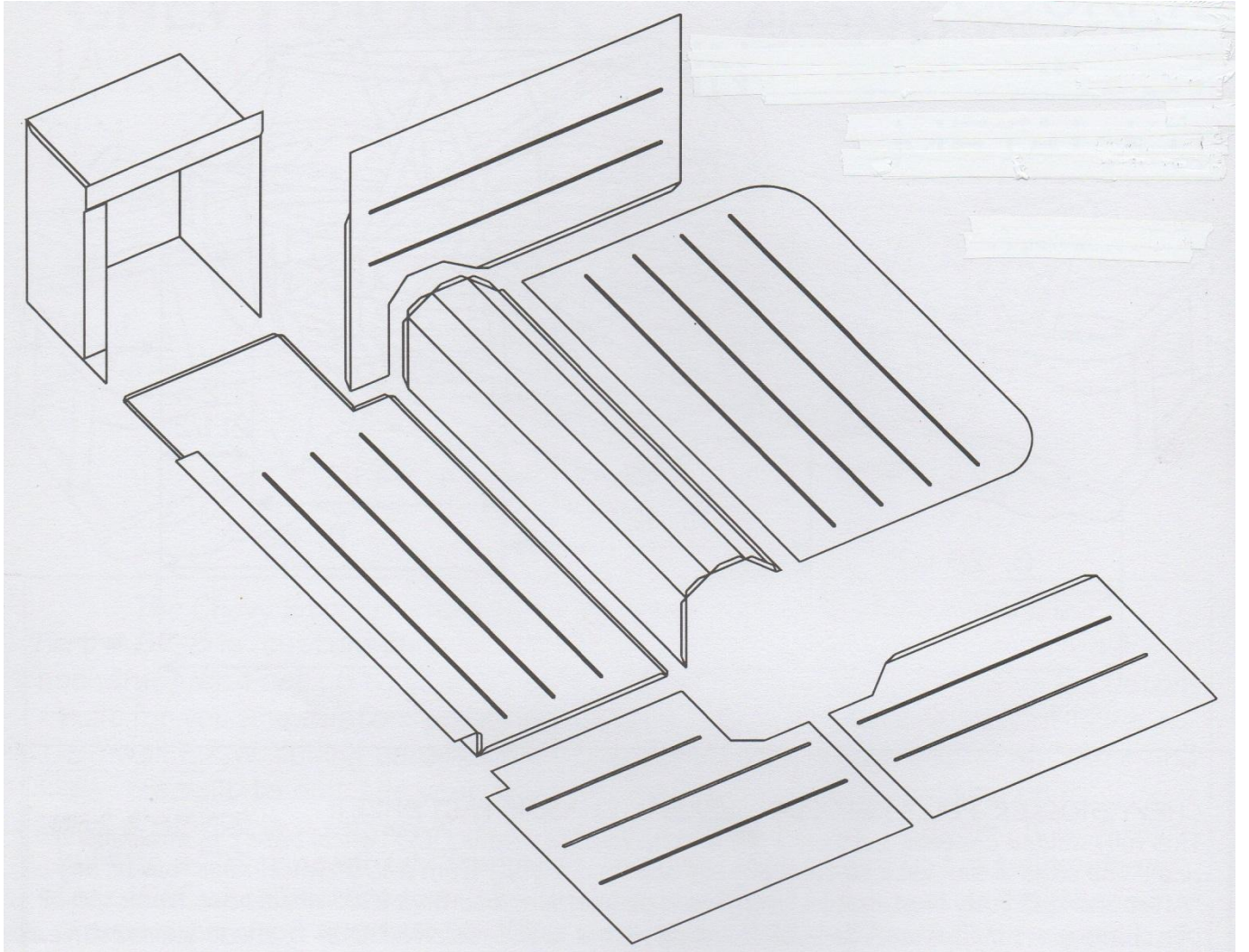

Diagram 4A

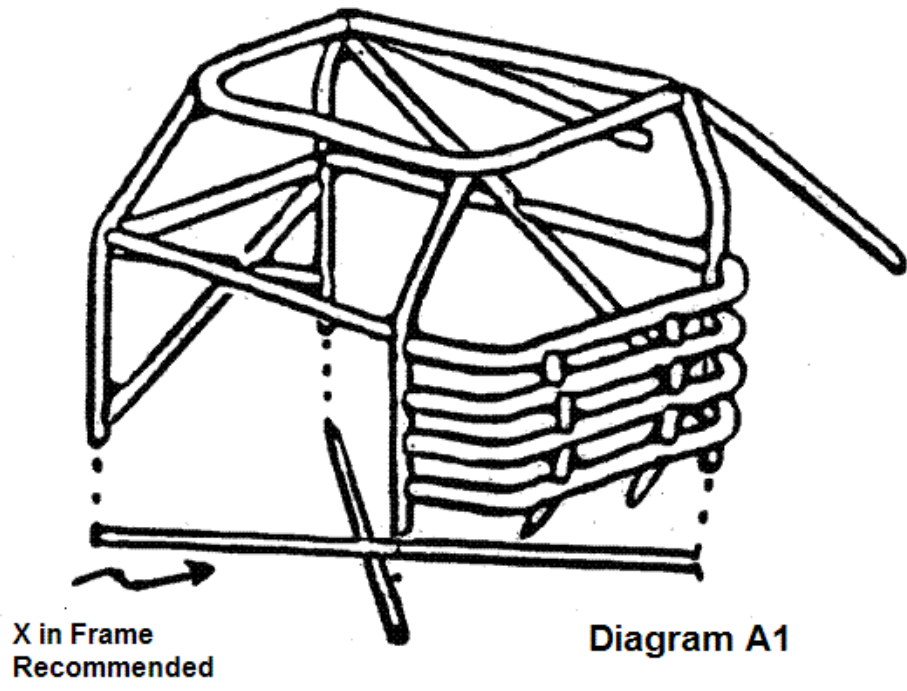

Figure A1

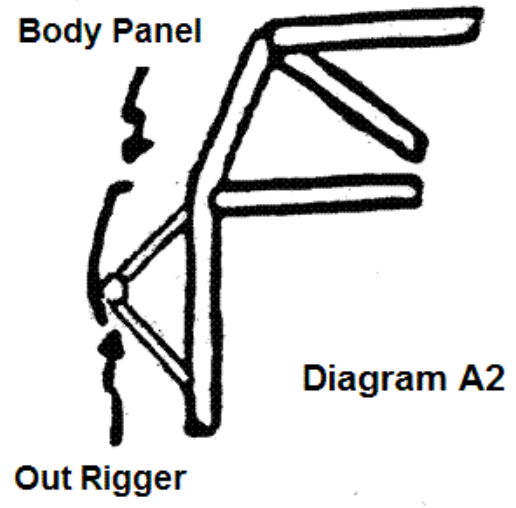

Figure A2

Appendix B

Diagram B1

Acceptable method of splicing tubing structure

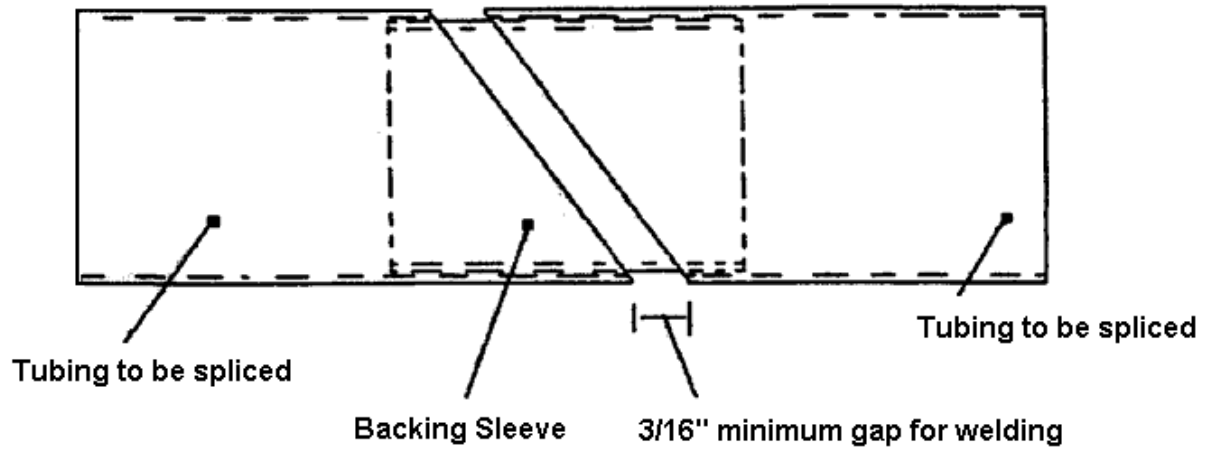

Figure B1

Tubing supported bumpers or covers

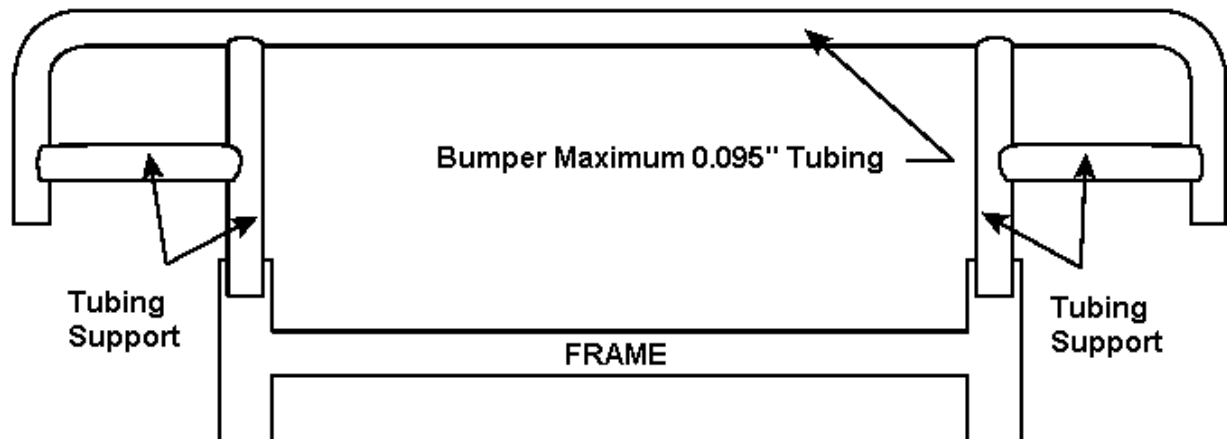

Figure B2

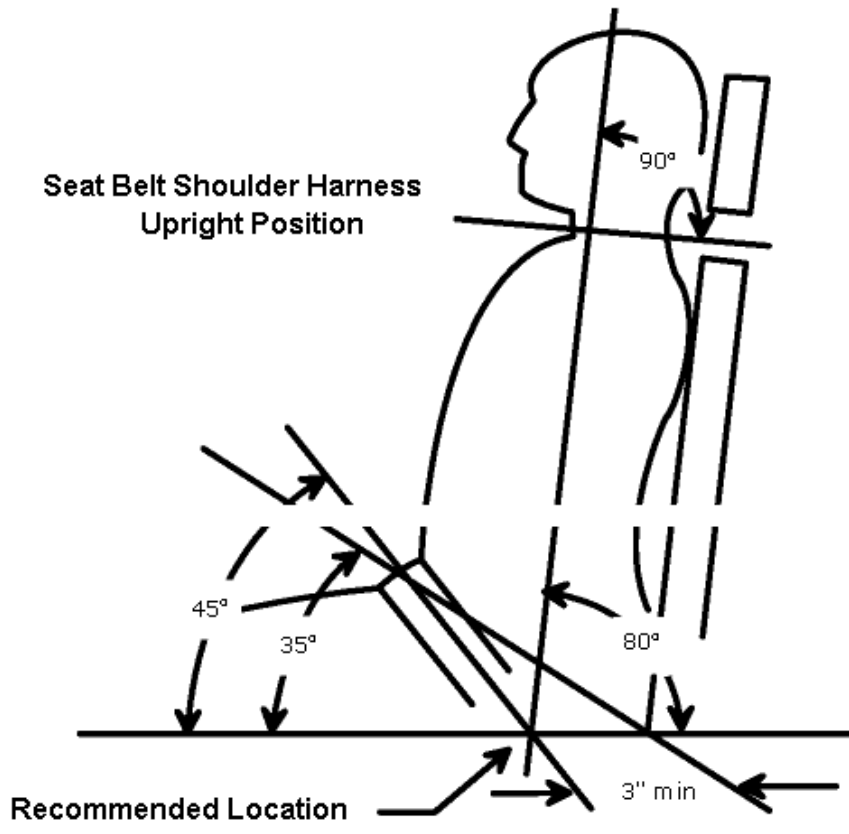

Figure C1

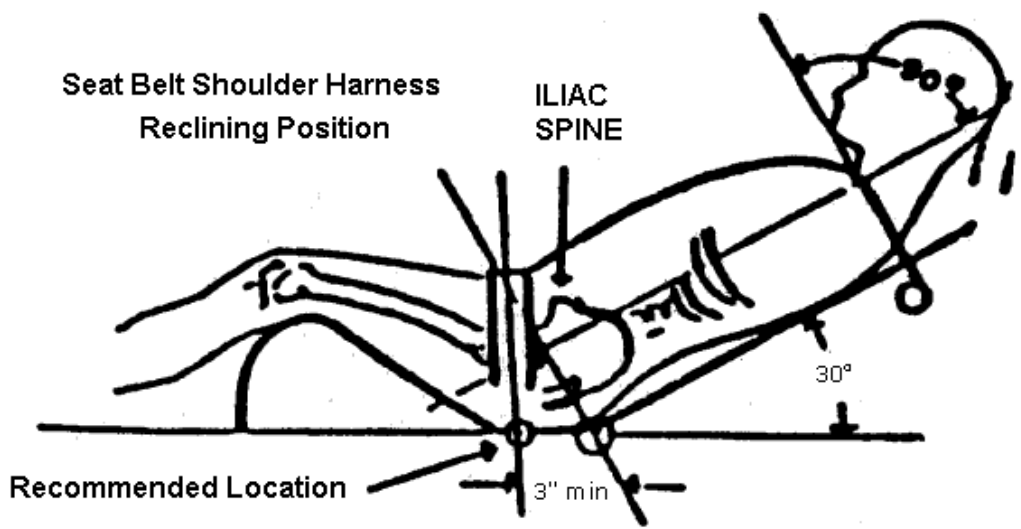

Figure C2

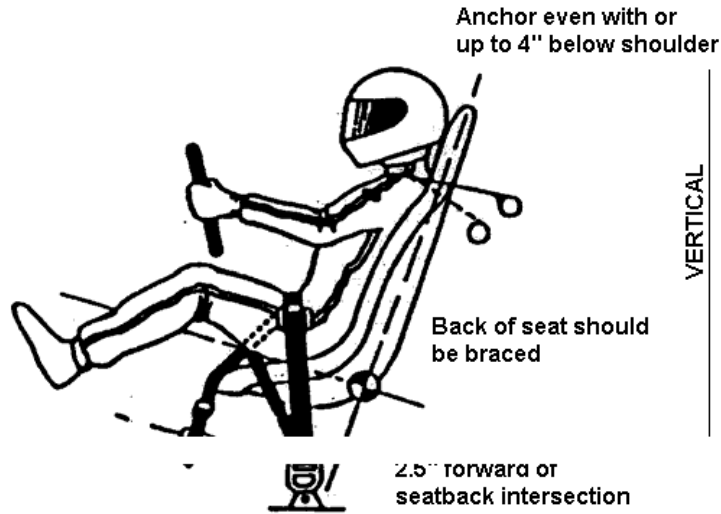

Figure C3

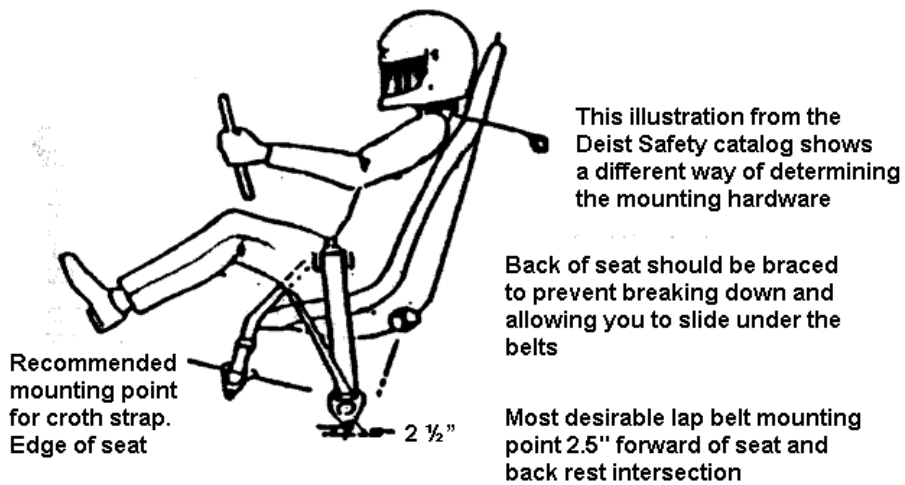

Figure C4

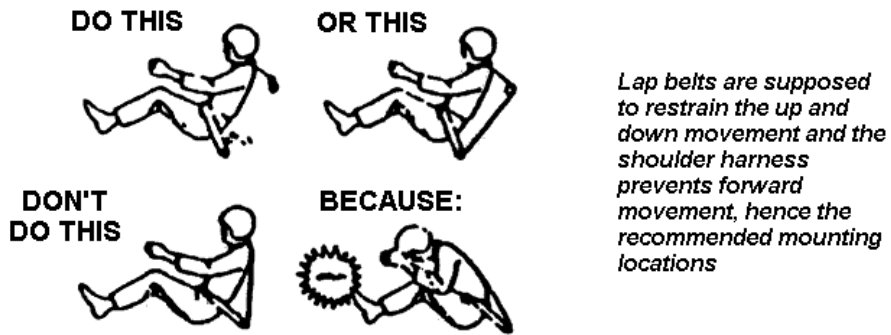

Figure C5



Diagram 5A

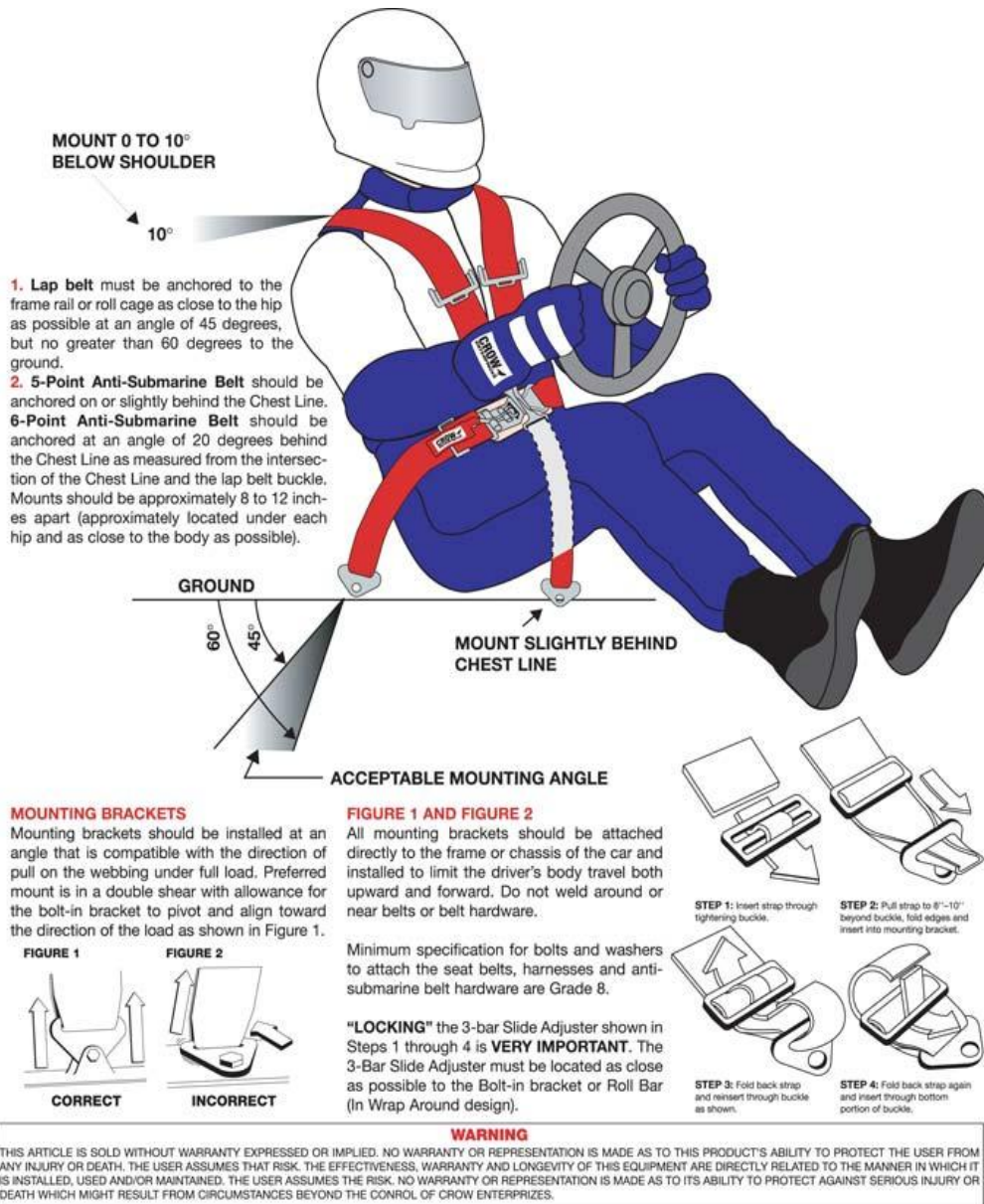

Diagram 5B



Seat Mount Diagram 6A



Recommended Seat Diagram 6B

Saskatoon Stock Car Racing Association Protest Form



Race Date: _____

Division: Pro Late Model Super Stock
 Pro Truck Street Stock
 Run-Your-Junk Bandolero

Protest Against (Name): _____

Protest For: _____

Reason for Complaint: _____

Protest Fee:

- \$300 – chassis and suspension inspection or, clutch, transmission and differential ratio inspection.
- \$2,000 – Cylinder head, intake, camshaft, exhaust and carburetor (top end) inspection
- \$2,500 – Cylinder head, intake, camshaft, exhaust, carburetor, oil pan, one connecting rod, one piston and crankshaft (bottom end inspection)
- \$1,000 + \$250 shop supply deposit – Dyno testing of sealed crate engine for horse-power rating only
- \$250 – Competition surcharge applies

Protester's Name: _____

Protester's Signature: _____

Cash Collected By: _____

Technical Inspector/ Race Director Signature: _____

Protest Results: _____

⇒ **Protest forms must be turned in to the Technical Inspector or Race Director 30 minutes after the conclusion of the final race.**

⇒ **All teardowns will be arranged with all parties.**